

250P1 ***Security System***

Installation and Setup Guide

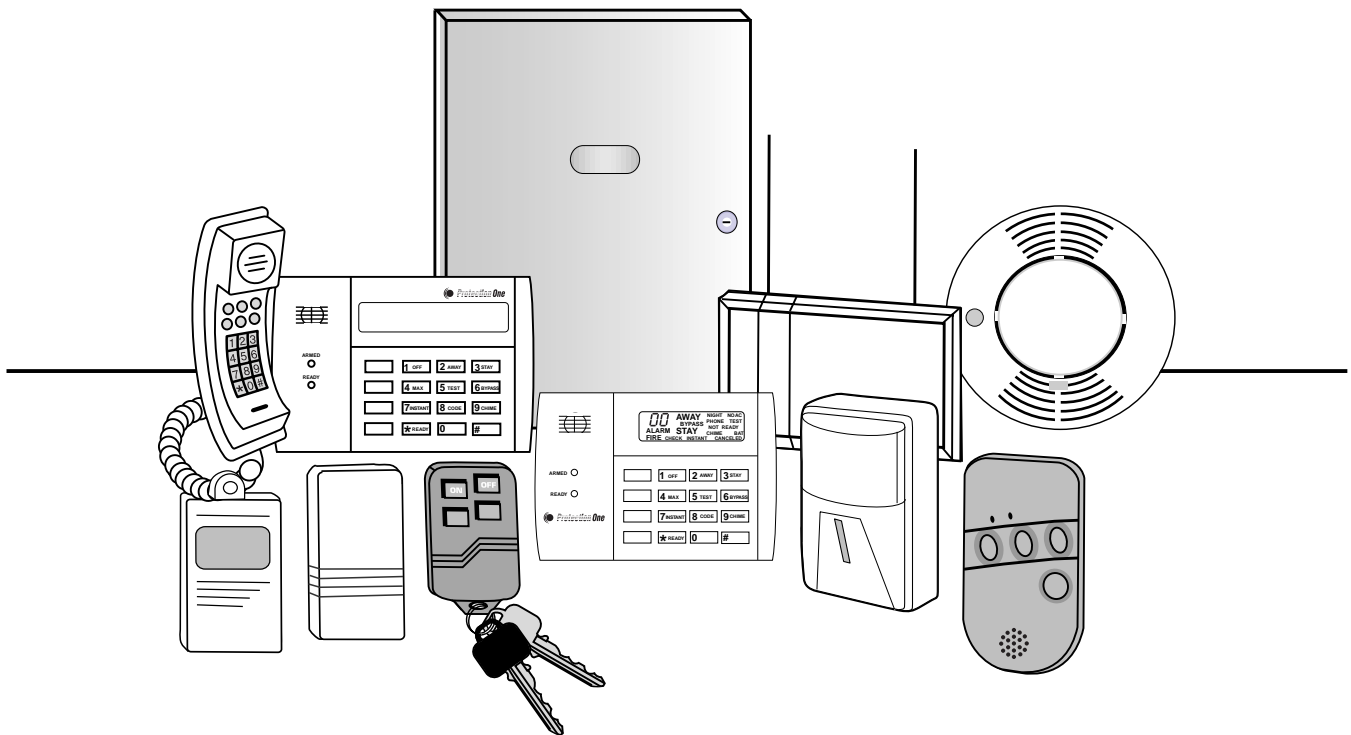

RECOMMENDATIONS FOR PROPER PROTECTION

The Following Recommendations for the location of Fire and Burglary Detection Devices Help Provide Proper Coverage for the Protected Premises.

Recommendations for Smoke and Heat Detectors

With regard to the number and placement of smoke/heat detectors, we subscribe to the recommendations contained in the National Fire Protection Association's (NFPA) Standard #72 noted below.

Early warning fire detection is best achieved by the installation of fire detection equipment in all rooms and areas of the household as follows: For minimum protection, a smoke detector should be installed outside of each separate sleeping area and on each additional floor of a multi-floor family living unit, including basements. The installation of **smoke detectors** in kitchens, attics (finished or unfinished), or in garages is not normally recommended.

For additional protection, the NFPA recommends that you install **heat or smoke detectors** in the living room, dining room, bedroom(s), kitchen, hallway(s), attic, furnace room, utility and storage rooms, basements, and attached garages.

In addition, we recommend the following:

- Install a smoke detector inside every bedroom where a smoker sleeps.
- Install a smoke detector inside every bedroom where someone sleeps with the door partly or completely closed. Smoke could be blocked by the closed door. Also, an alarm in the hallway outside may not wake up the sleeper if the door is closed.
- Install a smoke detector inside bedrooms where electrical appliances (such as portable heaters, air conditioners, or humidifiers) are used.
- Install a smoke detector at both ends of a hallway if the hallway is more than 40 feet (12 meters) long.
- Install smoke detectors in any room where an alarm control is located, or in any room where alarm control connections to an AC source or phone lines are made. If detectors are not so located, a fire within the room could prevent the control from reporting a fire or an intrusion.

THIS CONTROL COMPLIES WITH NFPA REQUIREMENTS FOR TEMPORAL PULSE SOUNDING OF FIRE NOTIFICATION APPLIANCES.

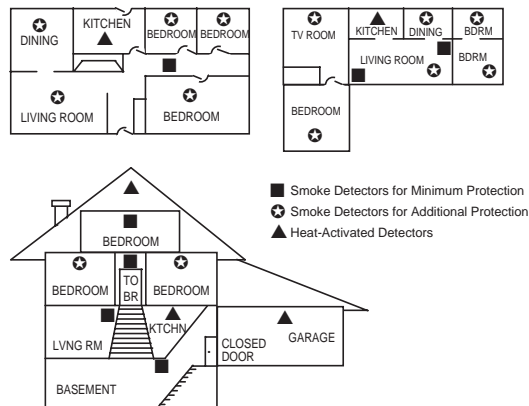

Recommendations for Proper Intrusion Protection

For proper intrusion coverage, sensors should be located at every possible point of entry to a home or commercial premises. This includes skylights and upper windows in a multi-level building.

In addition, we recommend that radio backup be used in a security system so that alarm signals can still be sent to the alarm monitoring station in the event that the telephone lines are out of order (alarm signals are normally sent over the phone lines, if connected to an alarm monitoring station).

Table of Contents

Conventions Used In This Manual	viii
SECTION 1 Introduction	1-1
Description	1-1
Features.....	1-1
SECTION 2 Installing the Control	2-1
Mounting the Cabinet	2-1
Installing the Lock (if used)	2-1
Mounting the Control's Circuit Board Alone in the Cabinet	2-2
Mounting Control and RF Receiver Circuit Boards Together in the Cabinet	2-3
Standard Phone Line Connections	2-4
Wiring the AC Transformer	2-5
Installing the Backup Battery	2-6
Earth Ground Connections	2-6
SECTION 3 Installing Remote Keypads	3-1
Keypads That May Be Used.....	3-1
Wiring to the Keypads.....	3-1
Mounting the Keypads	3-2
Supplementary Power for Additional Keypads	3-2
Preliminary Checkout Procedure	3-3
SECTION 4 Basic Hardwired Zones 1-6	4-1
Installing the Hardwired Zones.....	4-1
Programming Hardwired Zones	4-4
Checkout Procedure for Hardwired Zones	4-4
SECTION 5 Wired Zone Expansion	5-1
Installing Zone Expansion Units.....	5-1
Connections and Setup.....	5-1
Programming Wired Expansion Zones.....	5-3
Checkout Procedure for Wired Expansion Zones	5-3
SECTION 6 Wireless Expansion (5800 System)	6-1
About Wireless Expansion	6-1
Installing the 5881/5882 Receiver	6-2
Installing the 5800TM Module	6-3
Jam Detection and Reporting	6-3
About 5800 Series Transmitters.....	6-3
Installing 5800 Series Transmitters	6-6
SECTION 7 Relay Outputs & Powerline Carrier Devices	7-1
About Relays and Powerline Carrier Devices.....	7-1
4204 and 4229 Relay Modules	7-1
Powerline Carrier Devices	7-3
Programming Relay Outputs.....	7-4
SECTION 8 4285 & 4286 VIP Module	8-1
About the 4285 & 4286 VIP Module.....	8-1
Installing the Phone Module.....	8-1
Programming the 4285/4286 VIP Module.....	8-4
Checking 4285/4286 VIP Module Operation.....	8-4

SECTION 9 External Sounders	9-1
Compatible Sounders	9-1
NFPA Requirements.....	9-1
Sounder Connections and Power	9-2
Sounder Supervision	9-2
Testing the Sounder	9-2
SECTION 10 Long Range Radio	10-1
About Long Range Radio.....	10-1
Wiring Connections	10-1
Dynamic Signaling Feature	10-2
SECTION 11 Audio Alarm Verification (AAV) Unit	11-1
About Audio Alarm Verification	11-1
Wiring Connections	11-1
SECTION 12 Final Power-Up	12-1
Earth Ground Connections	12-1
AC Power-Up	12-1
Connecting the Backup Battery.....	12-1
Battery Tests.....	12-2
SECTION 13 Mechanics of Programming	13-1
About Programming	13-1
Entering Program Mode.....	13-2
Programming a Data Field	13-2
Reviewing a Data Field/Erasing an Entry.....	13-2
Interactive Mode Programming (★56, ★58, ★80, ★81, and ★82)	13-2
Loading Factory Defaults.....	13-3
Programming System Setup Fields.....	13-3
Exiting the Programming Mode	13-3
SECTION 14 Zone Response Type Definitions	14-1
Zone Type Definitions.....	14-1
SECTION 15 Data Field Descriptions	15-1
Descriptions of System Data Fields.....	15-1
SECTION 16 Zone Programming	16-1
About Zone Programming	16-1
★56 Zone Programming Procedures.....	16-1
★58 Expert Programming Mode Procedures	16-4
To Remove a Zone.....	16-6
To Delete a Transmitter Serial Number	16-7
To Enter and Duplicate Wireless Keys	16-7
SECTION 17 Output Device Programming	17-1
Programming Options Defined	17-1
Programming Output Relays and Powerline Carrier Devices.....	17-3
SECTION 18 Zone Lists	18-1
About Zone List Menu Mode	18-1
Zone List Displays	18-1
Cross Zoning - Zone List 04.....	18-2
NIGHT-STAY - Zone List 05.....	18-2
Pager Reporting - Zone List 06	18-2

SECTION 19 Alpha Descriptor Programming	19-1
About Alpha Descriptor Programming.....	19-1
Zone Descriptors.....	19-1
Programming Zone Descriptors (Program Menu Mode *82)	19-1
Adding Custom Words.....	19-3
SECTION 20 Function Key Programming (*83, *86)	20-1
About Function Key Programming.....	20-1
Programming Procedures (*83).....	20-1
Special Function Programming (*86)	20-2
Macro Key (Speedkey) Programming.....	20-3
SECTION 21 Remote Programming and Control (Downloading)	21-1
About Remote Programming.....	21-1
Equipment Required	21-1
Initial Download	21-2
Remote Programming Commands.....	21-2
Remote Programming Advisory Notes.....	21-2
SECTION 22 System Communication	22-1
Panel Communication with Central Station.....	22-1
Report Code Formats.....	22-1
SECTION 23 System Operation	23-1
Security Codes	23-1
Keypad Functions.....	23-2
Setting the Real-Time Clock	23-6
SECTION 24 Testing the System	24-1
Test Procedure	24-1
SECTION 25 Troubleshooting Guide	25-1
SECTION 26 Specifications & Accessories	26-1
Specifications	26-1
Accessories (Compatible Devices).....	26-3
APPENDIX A 5800 RF System Wireless Transmitters	A-1
Transmitter Input Loop Identification.....	A-1
APPENDIX B Regulatory Agency Statements	B-1
APPENDIX C Warnings and Limitations	C-1
Index	Index-1
List of Figures	vii
Programming Form	Insert

List of Figures



Figure 1. Installing the Cabinet Lock 2-1

Figure 2. Mounting the PC Board..... 2-2

Figure 3. Mounting the PC Board and RF Receiver Together in the Cabinet..... 2-3

Figure 4. Telephone Line Connections 2-4

Figure 5. Connections of 4300 Transformer to the Control Board 2-5

Figure 6. Keypad Connections to the Control Board..... 3-2

Figure 7. Using a Supplementary Power Supply for Keypads 3-3

Figure 8. 2-Wire Smoke Detector Connected to Zone 1..... 4-2

Figure 9. 4-Wire Smoke Detector Connections (Zones 2-6)..... 4-3

Figure 10. Wiring Connections - 4219 Expansion Module..... 5-2

Figure 11. Wiring Connections - 4229 Expansion/Relay Module 5-2

Figure 12. 5881/5882 RF Receiver (cover removed) 6-2

Figure 13. 4229 Connections to Control 7-2

Figure 14. 4204 Connections to Control 7-3

Figure 15. 4300 Transformer Wiring Connections 7-4

Figure 16. 4285/4286 VIP Module Wiring Connections 8-3

Figure 17. Typical Sounder Wiring..... 9-2

Figure 18. Bell Supervision Wiring 9-2

Figure 19. Long Range Radio Connections 10-1

Figure 20. Connection of AAV Unit When Not Using a 4285/4286 VIP Module 11-2

Figure 21. Connection of AAV Unit When Also Using a 4285 or 4286 VIP Module 11-2

Figure 22. 250P1 Summary of Connections..... Inside Back Cover

Conventions Used In This Manual

Before you begin using this manual, it is important that you understand the meaning of the following symbols:



A UL note includes specific information that must be followed if you are installing this system for a UL Listed application.



A checked note includes information you should be aware of before continuing with the installation, and which, if not observed, could result in operational difficulties.



This symbol warns of conditions that could seriously affect the operation of the system, or cause damage to the system. Please read each warning carefully. This symbol also denotes warnings about physical harm to the user.

Enter Zone Num.
(00 = Quit)

You may program many system options by responding to alpha keypad display prompts. These prompts are shown in a double-line box.

*00

When programming the system, data fields are indicated by a “star” (*) followed by the data field number.

PRODUCT MODEL NUMBERS: Unless noted otherwise, references to specific model numbers represent ADEMCO products.

Introduction

In This Section

◆ *Description*

◆ *Features*

Description

The 250P1 is a security system control that supports up to 32 zones, including six basic hardwired zones (1 through 6) and a maximum of 26 expansion zones. These expansion zones may include up to eight hardwired zones, or up to 26 wireless zones if hardwired zones are not used. Three separate keypad-activated zones are also provided.

Features

Basic Hardwired Zones

Provides 6 basic hardwired zones having the following characteristics:

- EOLR supervision supporting N.O. or N.C. sensors
- Programmable response time (10, 350, or 700 milliseconds)
- Up to sixteen 2-wire smoke detectors on zone 1
- 4-wire smoke or heat detectors on zones 2 through 6 (as many as can be powered from Auxiliary Power on the control).

Optional Expansion Zones (26 total: up to 8 wired with 18 wireless, OR 26 wireless)

Wired Expansion:

Supports up to 8 additional wired zones using a 4219 Expansion Module or 4229 Expansion/Relay Module. These zones have the following characteristics:

- EOLR supervision supporting N.O. or N.C. sensors
- 300–500mSec normal response with an option for fast (10–15mSec) response on loop A (first expansion zone).

Wireless Expansion:

Supports up to 26 wireless zones (fewer if using wired expansion zones).

- Requires the use of a 5881 (5882 in Canada) type RF receiver, as indicated below:

<u>Receiver Model</u>	<u>No. of Zones</u>
5881L/5882L	Up to 8
5881M/5882M	Up to 16
5881H/5882H	Up to 26

- Requires the use of 5800 Series Wireless Transmitters.

Remote Keypads

Up to 4 of any of the following keypads may be used in the installation:

Fixed-Word Keypad: 6148PL2, 6150PL2, 6150RFPL2,
 Alpha keypad: 6160PL2 (2-line alphanumeric displays)



To program from a keypad, you must connect a 6160PL2 (2-line alpha keypad), but it need not stay in the system.

Security Codes

- First Installer Code (user 1)
- One Master code for entire system (user 2)
- 11 Secondary User codes (users 3–13)
- One Temporary code (user 14)
- One Duress code (user 15).
- Second Installer Code (user 16).



Temporary Code: A special code that can be used to disarm and arm the system until the Master code is entered.

Duress Code: An emergency code that, when entered by *any* user, will send a silent duress message to the Central Station.

Keypad Panic Keys

- Up to 3 programmable panic key functions provided
- Designated as zones 95, 96, 99
- Activated by wired and wireless keypads
- Distinguished by subscriber ID number.

Zone Monitor Features

- The control will sense a high resistance in the loops on hardwired zones 2–6 if present, and will display a trouble message (rather than an alarm) for the affected zone when the system is in the disarmed mode.
- This system contains a Hardwire Short Detection circuit, and when enabled, detects a short in any wired zone and sends a Sensor Trouble message to the Central Station when the system is in the disarmed mode. At the same time a **CHECK** message is displayed on the keypad.

In both cases (high resistance or short detected on any zone), prevents the system from being armed until the offending condition is cleared.

Exit Error False Alarm Prevention Features

- Enables the system to determine the difference between an actual alarm and an alarm caused by leaving an entry/exit or interior zone open after the Exit Delay expires. If not disarmed in time, an alarm will sound and an Exit Error report will be sent to the Central Station.
An exit alarm condition will also occur if an entry/exit or interior zone re-opens within 2 minutes after the end of an Exit Delay.
- The 250P1 contains an Exit Restart feature which allows the user to exit (fault), close the door (restore the fault), then re-enter (fault again) the premises within the exit delay time period. Upon re-entering, a new exit delay time period is begun with the keypad annunciating three rapid beeps. This feature allows only one restart of the exit delay time for each arming session.

Optional Output Relays and Powerline Carrier Devices (X10 type)

- Maximum of 4 Output Devices
- Up to 4 relays using one 4204 Relay Module
- Up to 2 relays using one 4229 Zone/Relay Module
- Up to 4 Powerline Carrier devices (you must subtract the number of relay outputs actually used by the 4204 or 4229 modules, if used)
- Actions programmable to respond to zone activity or manual keypad entries.



Powerline Carrier devices require the use of the optional 4300 Transformer Module instead of the supplied 1321 AC Transformer.

Optional Phone Module

- Supports the ADEMCO 4285/4286 VIP Module (refer to **Section 8** for further information).
- Provides access to the system via on-premises or off-premises phones for arming, disarming, etc., plus control of relay outputs and Powerline Carrier devices.

Paging Feature

If programmed, the paging feature allows certain system conditions to be reported to a pager. Up to 16 digits may be programmed to be sent as a message to the pager. A 7-digit code following the programmed message indicates the type of condition that has occurred.

Audio Alarm Verification (AAV) Option

- Provides a programmable Audio Alarm Verification (AAV) option, which can be used in conjunction with an output relay to permit voice dialog between an operator at the Central Station and a person at the premises.
- Requires the use of optional AAV unit, such as Eagle Model 1250.

UL

The AAV option may not be used in UL installations.

Optional Long Range Radio

Allows all messages that have been programmed to go to the primary telephone number to be reported additionally to a 7720PLUS or 7820 Radio. Check availability of these models.

Built-in Telephone Line Monitoring Option

You can monitor telephone line voltage to supervise the phone line connection. You must connect the panel to a proper earth ground or you will get a false line cut indication if this feature is enabled.

The loss of the line can optionally cause a local display, or a display and trouble sound.

Event Logging

Keeps a record of up to 48 selected events in a history log. All control and readout from the log is done via ADEMCO COMPASS software **only**.

Alarm Output

- Provides a 12VDC, 2 amp output that can drive the compatible sounders listed in **Section 9: External Sounders** (assuming a fully charged battery is connected).
- Steady output for burglary/panic, or temporal pulse output (3 pulses – pause – 3 pulses – pause – 3 pulses . . .) for fire.
- Uses current-limiting circuitry for protection.

Auxiliary Power Output

- Provides 12VDC, 600mA maximum. Uses current-limiting circuitry for protection.
- Interrupts for smoke detector reset if 4-wire smoke detectors are used.

Programming

Programmed options are stored in electrically erasable, nonvolatile EEPROM memory (information can be reprogrammed at any time and will not be lost in the event of a power loss).

The system can be uploaded, downloaded, or controlled via an IBM-compatible computer, COMPASS software, and a modem specified by ADEMCO.

Keypad programming consists of:

- Data field programming
- Interactive (menu) mode programming



To program from a keypad, you must connect a 6160PL2 (2-line alpha keypad), but it need not stay in the system.

Communication Formats Supported

- ADEMCO Contact ID.

Zone Descriptors

You can assign alpha descriptors to all zones (only when using alpha keypads).

AC Power Supply

Uses 1321, 110VAC plug-in transformer with 16.5VAC 25VA output, unless Powerline Carrier devices (for example, X10 type) are used, in which case a 4300 Transformer Module must be used.

Backup Battery

Rechargeable (Sealed Lead Acid) 12VDC, 4AH minimum.

Installing the Control

In This Section

- ◆ *Mounting the Cabinet*
- ◆ *Installing the Lock*
- ◆ *Mounting the Control's Circuit Board Alone in the Cabinet*
- ◆ *Mounting the Control and RF Receiver Circuit Boards Together*
- ◆ *Standard Phone Line Connections*
- ◆ *Wiring the AC Transformer*
- ◆ *Installing the Backup Battery*
- ◆ *Earth Ground Connections*

Mounting the Cabinet

Using fasteners or anchors (not supplied) to mount the control cabinet to a sturdy wall in a clean, dry area that is not readily accessible to the general public. Four mounting holes are provided at the back of the cabinet.

If an RF receiver is being used and you intend to mount its PC board within the cabinet, note the following:

- Do not mount the cabinet on or near metal objects. This will decrease RF range and/or block RF transmissions from wireless transmitters.
- Do not locate the cabinet in an area of high RF interference (revealed by frequent or prolonged lighting of the LED in the receiver after it is operational (random flicker is OK).

Installing the Lock (if used)

Use an ADEMCO No. N6277 Cam Lock and No. N6277-1 Push-On Clip (Retainer Clip).

NOTE: The cabinet can be closed and secured without a lock by using 2 screws in the cover's edge.

To install the lock, perform the following steps:

1. Remove the cabinet door. It is easily removed for servicing and is easily re-installed.
2. Remove the lock knockout from the control cabinet door. Insert the key into the lock. Position the lock in the hole, making certain that the latch will make contact with the latch bracket when the door is closed.
3. Hold the lock steady and insert the retainer clip into the retainer slots. Position the clip as illustrated in order to permit easy removal.

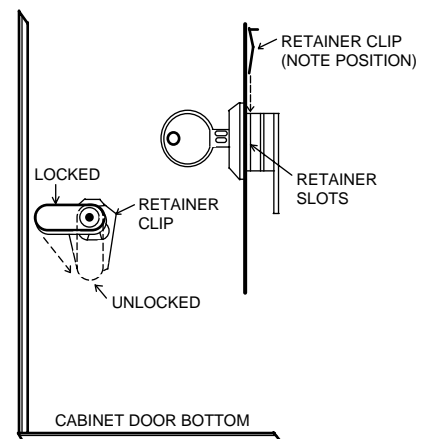

Figure 1. Installing the Cabinet Lock



Before installing the cabinet's contents, remove the metal cabinet knockouts required for wiring entry. Do not attempt to remove the knockouts after the circuit board has been installed.

Mounting the Control's Circuit Board Alone in the Cabinet

To mount the circuit board alone in the cabinet, follow these steps:

1. Hang two black mounting clips (provided) on the raised cabinet tabs (see Detail B in Figure 2).
2. Insert the top of the circuit board into the slots at the top of the cabinet. Make sure that the board rests on the correct row (see Detail A).
3. Swing the base of the board into the mounting clips and secure the board to the cabinet with the accompanying screws (see Detail B).

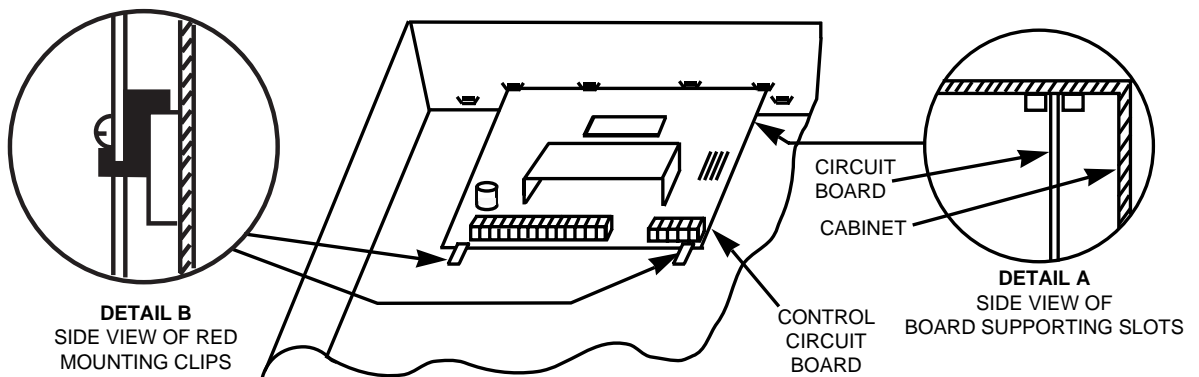

Figure 2. Mounting the PC Board

Mounting Control and RF Receiver Circuit Boards Together in the Cabinet

To mount the control and RF receiver boards together in the cabinet, do the following:

1. Hang two black mounting clips (provided with receiver) on the raised cabinet tabs, as shown in Detail B in **Figure 3**.
2. Insert the top of the receiver board (removed from its own case as described in its instructions) into the slots at the top of the cabinet, as shown in Detail A in **Figure 3**. Make sure that the board rests on the correct row of tabs, as shown.
3. Swing the base of the board into the mounting clips and secure it to the cabinet with the accompanying screws (see Detail B).
4. Insert the top of the control's board into the slot in the clips and position two red clips at the lower edge of the board (see Detail C).
5. Swing the board into place and secure it with two additional screws.
6. Insert grounding lugs (supplied with the receiver) through the top of the cabinet into the left-hand terminals of the antenna blocks (at the upper edge of the receiver board). Secure the grounding lugs to the cabinet top with the screws provided, as shown in Detail D.
7. Insert the receiver's antennas through the top of the cabinet, into the blocks' right-hand terminals, and tighten the screws.
8. Refer to **Section 6: Wireless Expansion (5800 System)** for receiver setup and wiring instructions.

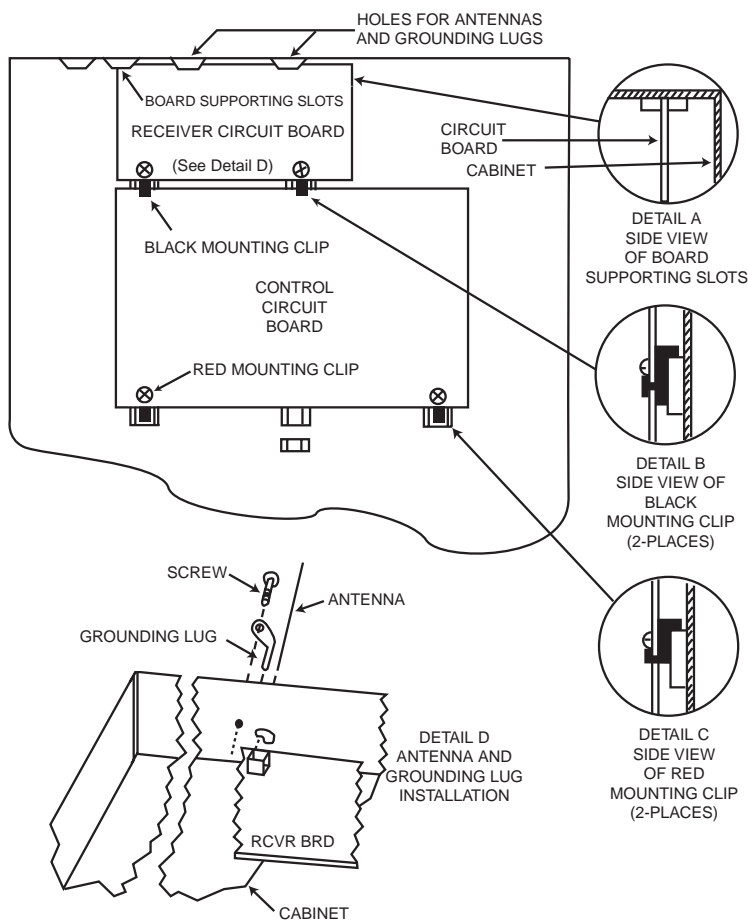

Figure 3. Mounting the PC Board and RF Receiver Together in the Cabinet

Standard Phone Line Connections



The wiring connections shown here are not applicable if the 4285/4286 VIP Module is used. Refer to **Section 8: 4285/4286 VIP Module** for information regarding phone line connections, which are different than those shown here.

Incoming phone line and handset wiring is connected to the main terminal block (via an RJ31X jack) as follows and shown in **Figure 4**:

- Term. 21: Local Handset (TIP – Brown*)
- Term. 22: Local Handset (RING – Gray*)
- Term. 23: Incoming Phone Line (TIP – Green*)
- Term. 24: Incoming Phone Line (RING – Red*)

* Colors of wires in Direct Connect Cord.

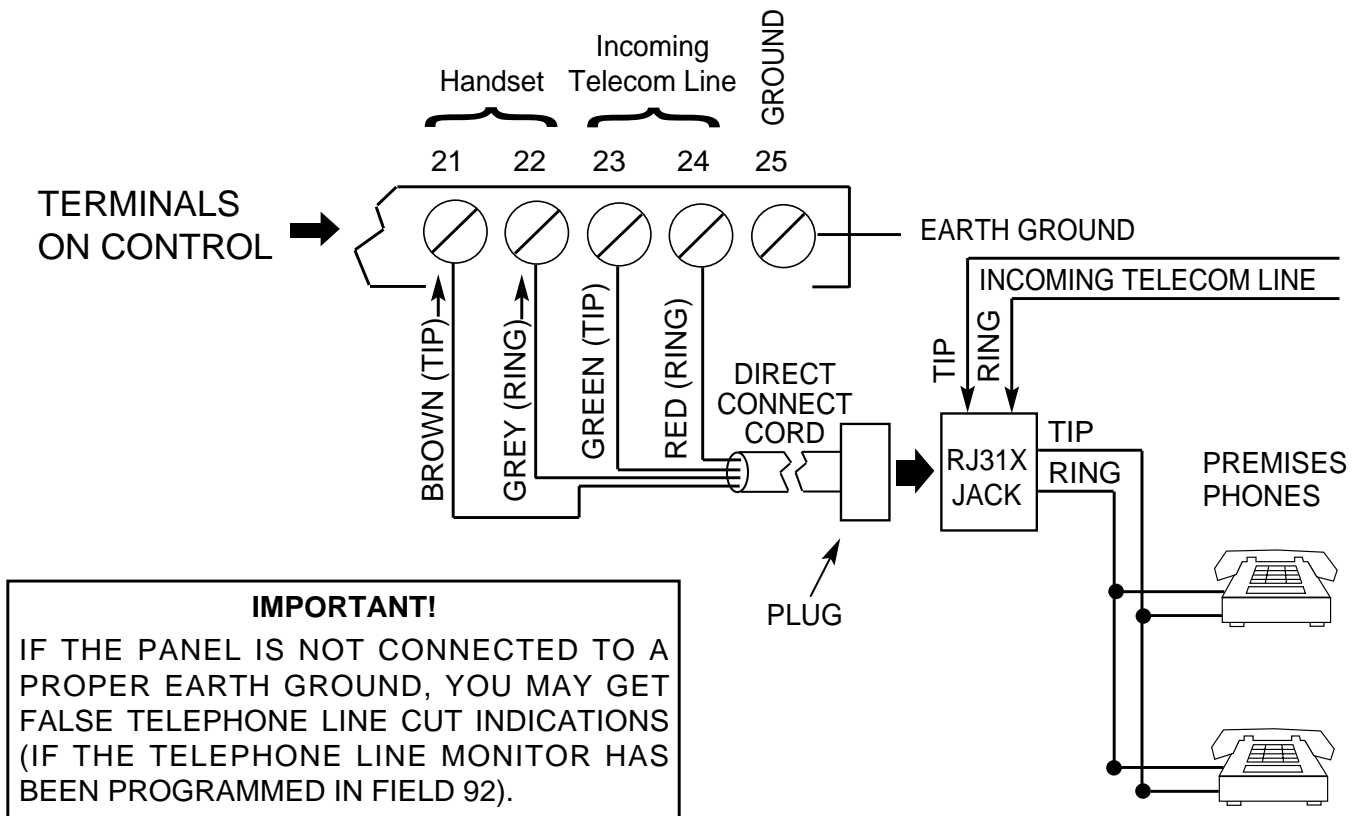

Figure 4. Telephone Line Connections

Wiring the AC Transformer

1321 Transformer

Wire the 1321 Transformer to terminals 1 and 2 on the control board. See wiring table below to determine wire gauge.

Use caution when wiring the transformer to the control panel to guard against blowing the fuse inside the transformer (the fuse is nonreplaceable).

4300 Transformer

If you are going to use a 4300 Transformer Interface (required if Powerline Carrier devices will be used), connect the 4300 Transformer's terminals as follows:

1. Connect terminals 1, 3 (AC), and 2 (Ground) to control board terminals 1, 2, and 25, respectively (see **Figure 5**). See table below to determine wire gauge to use.

WIRING TABLE	
Distance of Transformer From the Control Panel	Wire Gauge to Use
Up to 50 feet	# 20
50-100 feet	# 18
100-250 feet	# 16



Wiring to the AC transformer must not exceed 250 feet using 16-gauge wire. The voltage reading between terminals 1 and 2 of the control must not fall below 16.5VAC, or an **AC LOSS** message will be displayed.

Do not plug the transformer into the AC outlet until you are instructed to do so later in the manual.

2. Wire the other three terminals (Sync, Data, Com) on the 4300 Transformer. Wires from these terminals must be connected to a 9-pin connector on the control board (using a 4142TR Cable supplied with the 4300 Transformer), as shown in **Figure 5**. These particular wires can be 24-gauge or larger, and can be run along with the AC and ground wires to the control panel.

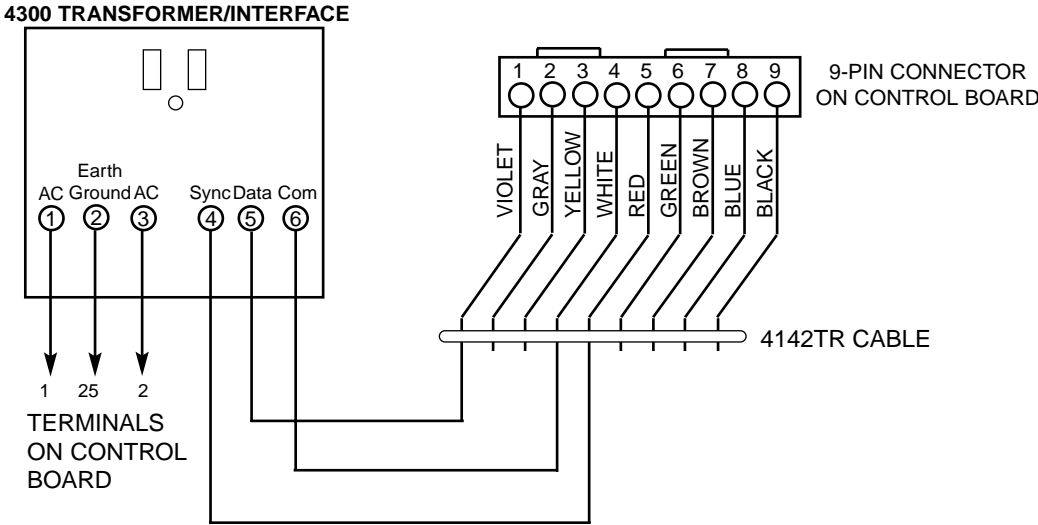

Figure 5. Connections of 4300 Transformer to the Control Board

Installing the Backup Battery

If necessary, refer to **Section 12: Final Power-Up** for information regarding battery size to use.



Do not attach the connector cable to the battery terminals until you are instructed to do so later in the manual.

Install the backup battery as follows:

1. Place the 12-volt backup battery in the control cabinet.
 2. Attach red and black wires on the battery connector cable as follows:
 - a. Red to the positive (+) battery terminal **on the control board** (see **Figure 22. 250P1 Summary of Connections** for location, if necessary).
 - b. Black to the negative (-) battery terminal **on the control board**.
-

UL

Use a 4AH battery or larger for UL installations.

Earth Ground Connections

The designated earth ground terminal (25) must be terminated in a good earth ground for the lightning transient protective devices in this product to be effective. The following are examples of good earth grounds available at most installations:

Metal Cold Water Pipe: Use a noncorrosive metal strap (copper is recommended) firmly secured to the pipe to which the ground lead is electrically connected and secured.

AC Power Outlet Ground: Available from 3-prong, 120VAC, power outlets only. To test the integrity of the ground terminal, use a 3-wire circuit tester with neon lamp indicators, such as the UL Listed Ideal Model 61-035, or equivalent, available at most electrical supply stores.

Installing Remote Keypads

In This Section

- ◆ Keypads That May Be Used
- ◆ Supplementary Power for Additional Keypads
- ◆ Wiring to the Keypads
- ◆ Preliminary Checkout Procedure
- ◆ Mounting the Keypads

Keypads That May Be Used

Up to 8 keypads may be used in the system, independent of auxiliary power considerations (you may need to use an auxiliary power supply if the 600mA aux. output is exceeded).

The following keypad models may be used:

- Fixed-Word Display: 6148PL2, 6150PL2, 6150RFPL2
- Alpha Display: 6160PL2

Wiring to the Keypads

To wire keypads to the control, perform the following steps:

1. Determine wire gauge by referring to the Wiring Run Chart below.

For devices (keypads, RF receivers, zone expander, etc.) connected to a single 4-wire run, determine the current drawn by all units connected to the single wire run, then refer to the Wiring Run Chart below to determine the maximum wire length that can be safely used for each wire size. Current draw for all devices can be found in **Section 26: Specifications & Accessories**.

NOTE: Refer to Table 1. AUXILIARY DEVICE CURRENT DRAW WORKSHEET in **Section 12: Final Power-Up** to obtain the current draw for all keypads.



Maximum wire lengths for any device that is home run to the control can also be determined from the Wiring Run Chart, based on the current draw of that device alone.

Wiring Run Chart for Devices* Drawing Aux Power from the Control (12V+ & 12V-)					
Wire Size	TOTAL CURRENT DRAWN BY ALL DEVICES CONNECTED TO A SINGLE WIRE RUN				
	50mA or less	100mA	300mA	500mA	600mA
#22	500 ft (152m)	250 ft (76m)	80 ft (24m)	50 ft (15m)	42 ft (13m)
#20	750 ft (228.6m)	380 ft (116m)	130 ft (39.6m)	80 ft (24m)	67 ft (20.4m)
#18	1300 ft (396m)	650 ft (198m)	220 ft (67m)	130 ft (39.6m)	115 ft (35m)
#16	1500 ft (457m)	1000 ft (305m)	330 ft (100.5m)	200 ft (70m)	170 ft (52m)

* Includes Keypads, RF Receivers, Zone Expander/Relay Units, or 4285/4286 VIP Module.



The length of all wire runs must not exceed 1500 feet (457m) when unshielded quad conductor cable is used (750 feet if shielded cable is used). This restriction is due to the capacitive effect on the data lines when quad cable is used.

2. Run field wiring from the control to the keypads (using standard 4-conductor twisted wire cable of the wire gauge determined in step 1).
3. Connect remote keypads to terminals 4, 5, 6, and 7 on the control board, as shown in **Figure 6**.

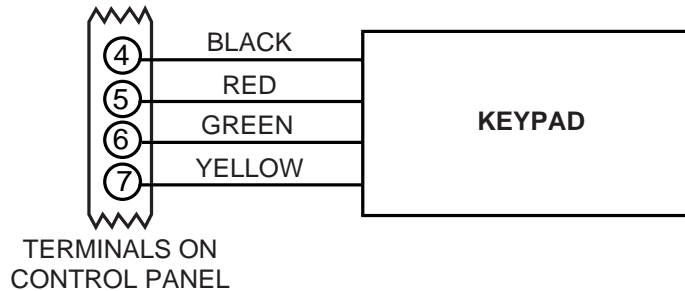

Figure 6. Keypad Connections to the Control Board

Mounting the Keypads

To mount the keypads, perform the following steps:

1. Make sure addressable-type keypads (6148PL2, 6150PL2, 6150RFPL2, or 6160PL2 are set to non-addressable mode (address 31), which is the factory default setting. Refer to the instructions provided with the keypad for address setting procedure.
2. Surface mount the keypad at a height that is convenient for the user. Refer to the mounting instructions and template included with the keypad for specific information.

Supplementary Power for Additional Keypads

The 250P1 control provides 600mA for powering keypads (up to 8) and other devices from the auxiliary power output. The backup battery will supply power to these keypads in the event that AC power is lost.

When the control's auxiliary power load for all devices exceeds 600 mA, you can power additional keypads from a regulated 12VDC Power Supply (e.g., 487-12 supplies 12V, 250mA; 488-12 supplies 12V, 500mA). Use a UL Listed, battery-backed supply for UL installations.

The 487-12/488-12 power supplies contain a backup battery that can power these keypads in the event of AC power loss to the main supply.



Keypads powered from supplies that do not have a backup battery **will not function** when AC power is lost. Therefore, be sure to power at least one keypad from the control's auxiliary power output.

Connect the additional keypads as shown in **Figure 7**, using the keypad wire colors shown. Be sure to observe the current ratings for the power supply used.



Make connections directly to the screw terminals as shown in Figure 7. Make no connection to the keypad blue wire (if present).

Be sure to connect the negative (-) terminal on the Power Supply unit to terminal 4 (AUX -) on the control.

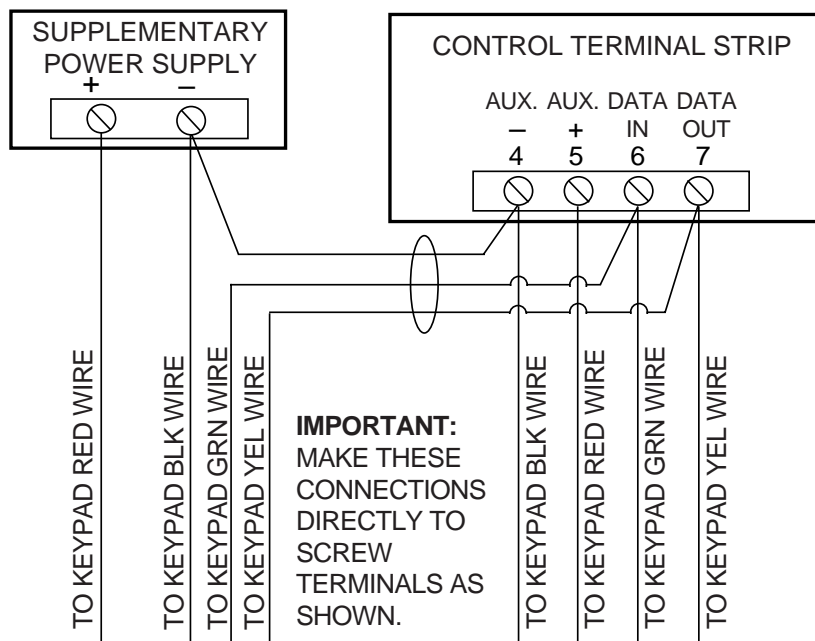

Figure 7. Using a Supplementary Power Supply for Keypads

Preliminary Checkout Procedure

To verify that the system is working before connecting field wiring from zones and devices, do the following:

1. Temporarily connect a 2000-ohm end-of-line resistor across each of the basic hardwired zones 1–6, as shown in the 250P1 Summary of Connections diagram.
Without actual zone wiring or EOL resistors connected, the keypads will not display the **READY** message.
2. Power up the system temporarily by plugging the AC transformer (previously wired to the control) into a 120VAC outlet.
Busy - Standby (on alpha keypads) or **dI** (on fixed-word keypads) will be displayed.

3. Wait approximately 1 minute. At that time, the green **READY** LED (or **POWER** LED on some types of keypads) should light, and the word **READY** (on fixed-word keypads), or **DISARMED...READY TO ARM** (on alpha keypads) should be displayed.

To bypass the 1-minute delay, press # plus **0**.

If the **READY** display does not appear on any of the keypads in the system, or a **NOT READY** message is displayed, check the keypad wiring connections, and make sure each of the 6 basic hardwired zones has a 2000 ohm resistor connected across its terminals.

When **READY** is displayed on the keypad(s), the system is functioning properly.

Do not remove the EOL resistors until you are ready to make connections to the hardwired zones, to allow for testing later in the manual.



If an **OC** or **OPEN-CIRCUIT** message is displayed on the keypad, data from the control is not reaching the keypad. Check the wiring.

Basic Hardwired Zones 1–6

In This Section

- ◆ *Installing the Hardwired Zones*
- ◆ *Programming Hardwired Zones*

- ◆ *Checkout Procedure for Hardwired Zones*

Installing the Hardwired Zones

Common Characteristics of Zones 1–6

- EOLR-supervised zones support both open-circuit and closed-circuit devices.
- As many 4-wire smoke detectors as can be powered from Aux Power on the control (zones 2–6).
- Programmable for 10, 350, or 700mSec response.
- 350mSec (default) should be used for most standard contacts. For vibration-type contacts, 10mSec is more suitable.

Wiring Burglary and Panic Devices to Zones 1–6

To wire burglary and panic devices to zones 1-6, perform the following steps, referring to **Figure 22. 250P1 Summary of Connections** at the back of this manual.

1. Connect sensors/contacts to the hardwired zone terminals (8 through 17).
2. Connect closed-circuit devices in series in the high (+) side loop. The EOL resistor must be connected in **series** with the devices, following the last device.
3. Connect open-circuit devices in parallel across the loop. The 2000-ohm EOLR must be connected **across** the loop wires at the last device.



If the EOLR is not at the end of the loop, the zone will not be properly supervised, and the system may not respond to an open-circuit on the zone.

High-Resistance/Short Supervision on Hardwired Zones 2–6

Special supervision in the control panel senses high resistance or a short on hardwired loops 2–6, causing a **FAULT** and the affected zone number to be displayed when the system is in the disarmed state. However, if the Hardwire Short Detection field *30 is enabled and the panel senses a short on the hardwired loops 2-6, **CHECK** and the affected zone number are displayed on the keypad when it is in the disarmed state. A Trouble report will also be sent to the Central Station. The system cannot be armed when a **FAULT** or **CHECK** condition is present. If the system is armed when a high-resistance or short condition occurs, an alarm will be generated for that zone.

Wiring 2-Wire Smoke Detectors to Zone 1

1. Connect 2-wire smoke detectors across zone 1 terminals 8 (+) and 9 (-). Observe proper polarity when connecting the detectors.
2. If an EOL resistor is presently connected across zone 1 terminals, remove it. **The EOL resistor must be connected across the loop wires at the last detector.**

UL

In UL installations, only zone 1 may be used as a fire zone. In addition, an ADEMCO Model 610-7 must be used as the end-of-line resistor at the last detector.



The alarm current provided by zone 1 will support only one smoke detector in the alarmed state.

COMPATIBLE 2-WIRE SMOKE DETECTORS

Detector Type	System Sensor Model No.
Photoelectric w/heat sensor, direct wire	2300TB
Photoelectric, direct wire	2400
Photoelectric w/heat sensor, direct wire	2400TH
Photoelectric	2451 w/B401B base
Photoelectric w/heat sensor	2451TH w/B401B base
Ionization, direct wire	1400
Ionization	1451 w/B401B base
Photoelectric duct detector	2451 w/DH400 base
Ionization duct detector	1451D w/DH400 base H
Low-profile, photoelectric, w/135°F thermal	2100T
Low-profile, ionization type, direct wire	1100



Figure 8. 2-Wire Smoke Detector Connected to Zone 1

Wiring 4-Wire Smoke/Combustion Detectors on Zones 2-6

The system will support as many 4-wire detectors as can be powered from Auxiliary Power on the control on zones 2-6. Refer to the detector's instructions for complete details regarding its proper installation and operation.

1. Connect 12-volt power for the detectors from Auxiliary Power terminals 4 and 5 (which will interrupt power for fire alarm reset). Observe proper polarity when connecting detectors.
2. Connect detectors (including heat detectors, if used) across terminals of the zone selected (zones 2-6 may be used). All detectors must be wired in parallel.



Remove 2000 ohm EOL resistor if connected across the selected zone terminals. You must connect the EOL resistor across the loop wires at the last detector.

To supervise power, we recommend the use of a System Sensor No. A77-716B Supervisory Module.

Compatible 4-Wire Smoke/Combustion Detectors	
System Sensor 1412	4-wire ionization products of combustion detector
System Sensor 2412	4-wire photoelectric smoke detector
System Sensor 2412TH	4-wire photoelectric smoke detector w/135° F (57° C) heat detector
System Sensor A77-716B	EOL relay module (supervisory module for wired 4-wire fire zone).
System Sensor 2112/24T	Low-profile 4-wire photoelectric smoke detector w/135° F (57° C) heat detector

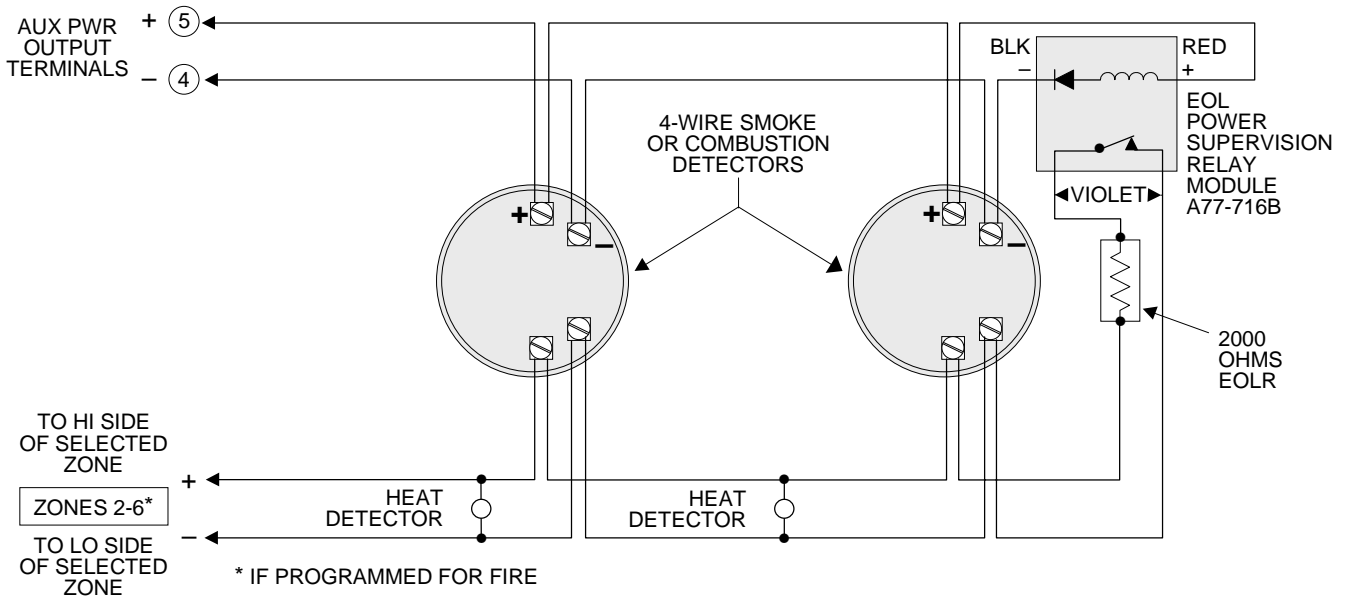

Figure 9. 4-Wire Smoke Detector Connections (Zones 2-6)

Verifying Smoke Detector Operation

The control panel will “verify” any alarm by resetting the smoke detectors after the first alarm trigger, and then waiting 90 seconds for a second alarm trigger. If the smoke detector or thermostat does not trigger again, the control will disregard the first trigger, and no alarm signal will occur. This feature eliminates false alarms due to electrical or physical transients.

Turning Off Fire Alarm Sounding

You can turn off fire alarm sounding by pressing the OFF key on any keypad or other arming/disarming device. To clear the “memory of alarm” and to reset the detector’s alarm, enter the security code plus OFF again.

Programming Hardwired Zones

Each zone must be programmed into the system using the *56 Zone Programming Mode or the *58 Programming Mode which assigns characteristics that define the way the system responds to faults on that zone. Refer to **Section 14: Zone Response Type Definitions** and **Section 16: Zone Programming** for specific instructions on programming hardwired zones.

Checkout Procedure for Hardwired Zones

After installation and programming of all hardwired devices is completed, the security system should be checked, as follows.

1. Make certain that all devices and sensors connected to the hardwired zones are not in a faulted state. Doors and windows with contacts should be closed, PIRs should be covered (use a cloth to mask them temporarily, if necessary).
2. Plug in the AC transformer if you have not already done so.

With all hardwired zones intact, the Alpha keypad connected to the system should display:

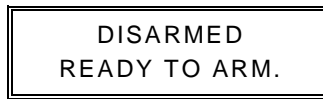

DISARMED
READY TO ARM.

3. If the following is displayed,

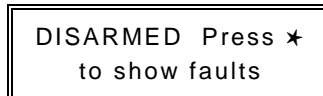

DISARMED Press *
to show faults

press * to display the faulted zone(s). Restore any faulted zone(s) as necessary (also make sure that you have connected a 2000 ohm EOL resistor across the terminals of unused zones).

When the **DISARMED...READY TO ARM** message is displayed, you can proceed to the next step.

4. Fault and then restore every contact or sensor on each zone individually to ensure that it is being monitored by the system. Each time a zone is faulted, the keypad should display the number of the faulted zone. When each zone is restored, the **READY TO ARM** message should appear again.

You will need to observe the keypad as each zone is faulted and restored.

When you get the proper displays on the keypad(s), the hardwired zones in the system are functioning properly.

5. Unplug the AC transformer.

Wired Zone Expansion

In This Section

- ◆ *Installing Zone Expansion Units*
- ◆ *Connections and Setup*

- ◆ *Programming Wired Expansion Zones*
- ◆ *Checkout Procedure for Wired Expansion Zones*

Installing Zone Expansion Units

You can add 8 wired EOLR zones to the basic control's 6 zones, for a total of 14 wired zones, by using a 4219 Wired Expansion Unit or 4229 Wired Expansion/Relay Unit.

- Location**
 - You can mount an expansion unit within the control cabinet if space permits. Otherwise, mount the unit outside the cabinet.
- Supervision**
 - Units are supervised against removal. Keypads will display **CHECK** and **ZONE 09** if a zone expander is disconnected.
 - Units have tamper protection for security when mounted outside of the cabinet.
- Zone Information**
 - Assign zone numbers 10–17 for the eight wired expansion loops (designated A to H in **Figure 10** and **Figure 11**). You can program these zones individually (in *56 Interactive Mode or *58 Expert Programming Mode). Expansion zones must also be programmed as input type 2 (AW) when prompted.

Connections and Setup

To add an expansion module, perform the following steps:

1. Connect the 4219 or 4229 module to the control's keypad terminals (see **Figure 10. Wiring Connections - 4219 Expansion Module** or **Figure 11. Wiring Connections - 4229 Expansion/Relay Module**).
2. Set the 4219 or 4229's DIP switch for device address "1" (switch 2 in the OFF position and switches 3, 4, 5 in the ON position). Switch 1 determines expansion zone A's response time (ON = normal response, OFF = fast response). For location of the DIP switch in both the 4219 and 4229 units, see figures that follow on next page.

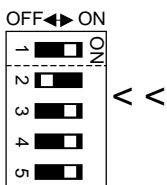

For additional information, see instructions supplied with the 4219 and 4229.

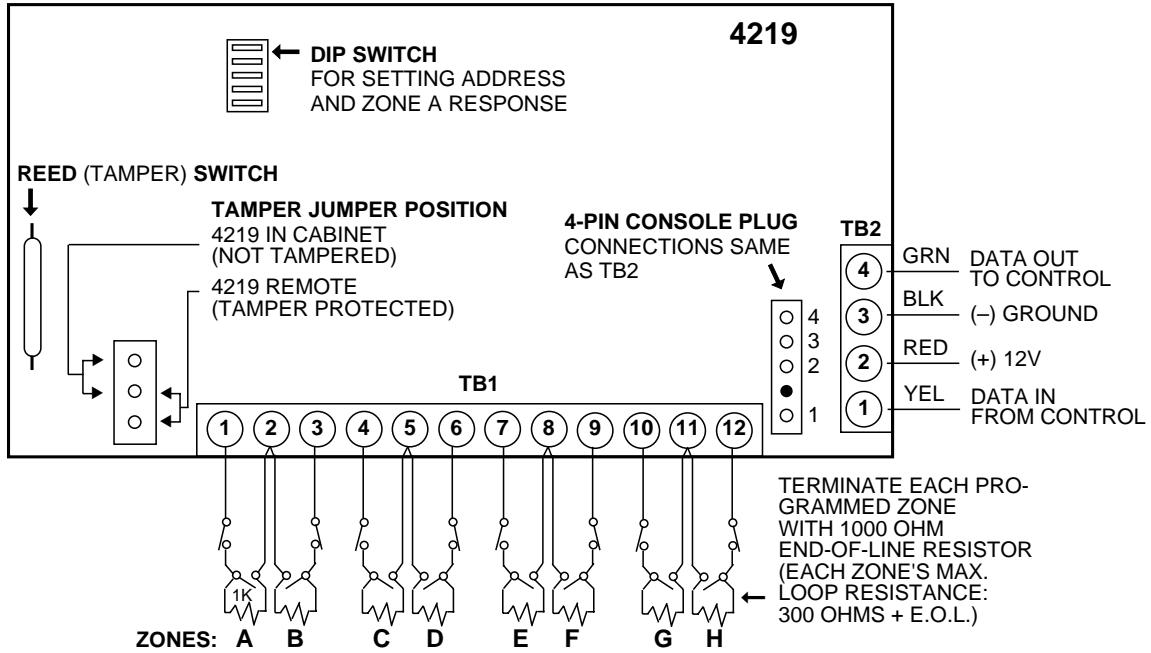

Figure 10. Wiring Connections - 4219 Expansion Module

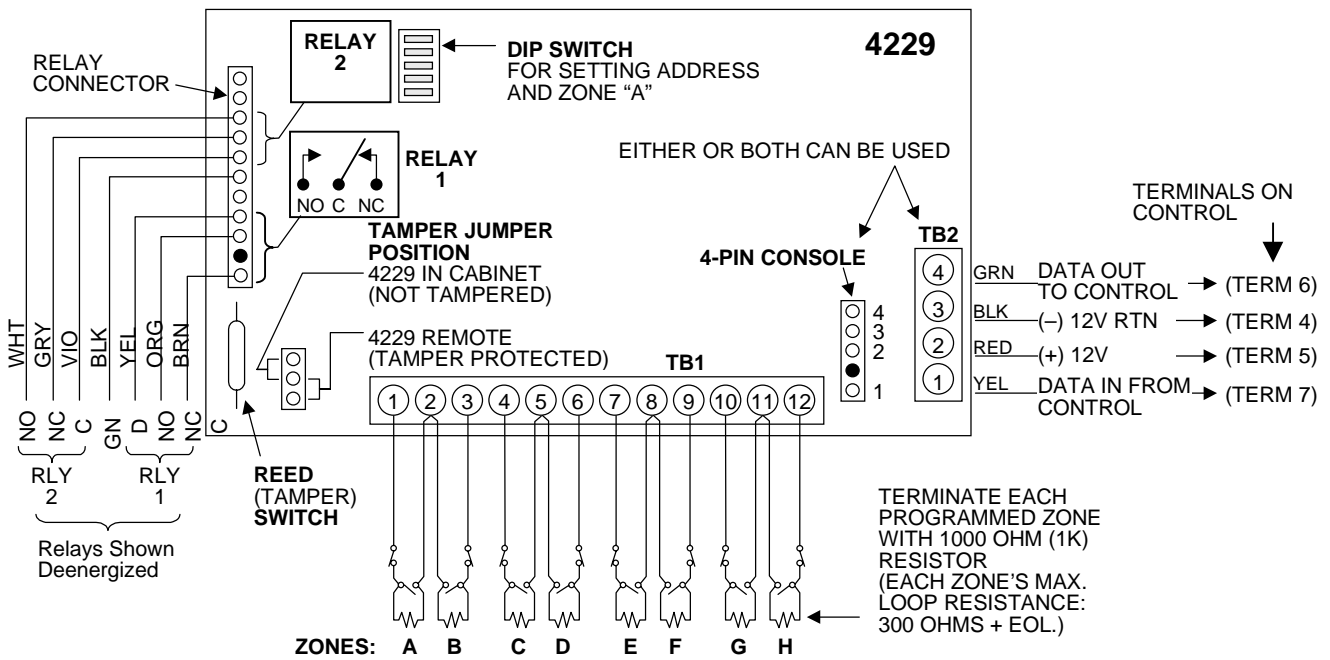

Figure 11. Wiring Connections - 4229 Expansion/Relay Module

Programming Wired Expansion Zones

Each zone must be programmed into the system using the *56 Zone Programming mode or *58 Expert Programming mode, both of which assigns characteristics that define the way the system responds to faults on that zone. Refer to **Section 14: Zone Response Type Definitions** and **Section 16: Zone Programming** for specific instructions on programming wired expansion zones.

Checkout Procedure for Wired Expansion Zones



Whenever it becomes necessary to disconnect power in order to add a module or keypad, always disconnect the battery first, then the AC transformer. After installation has been completed, connect the AC transformer first, then the battery.

After you have completed installation and programming of all devices, all expansion zones in the security system should be checked as follows:

1. Make certain that all devices and sensors connected to the wired expansion zones are not in a faulted state. Doors and windows with contacts should be closed, PIRs should be covered (use a cloth to mask them temporarily, if necessary).
2. Plug in the AC transformer. With all zones intact (including hardwired zones), the alpha keypad connected to the system should display:

DISARMED
 READY TO ARM.

3. If the following is displayed,

DISARMED Press •
 to show faults

press * to display the faulted zone(s). Restore any faulted zone(s) as necessary (also make sure that you have connected a 1000 ohm EOL resistor across the terminals of unused expansion zones on the 4219 or 4229 Module).

When the **READY TO ARM** message is displayed, you can proceed to the next step.

4. Fault and restore every contact or sensor in each expansion zone individually to ensure that it is being monitored by the system. Each time a zone is faulted, the keypad should display the number of the faulted zone. When each zone is restored, the READY TO ARM message should appear again.

You will need to observe the keypad in each zone, as each zone is faulted and restored.

When the proper displays appear on the keypad(s), the wired expansion zones in the system are functioning properly.

5. Unplug the AC transformer.

A **CHECK 09** message on the display signifies one of two problems:

- Data from the control is not reaching the zone expander module. Check the wiring and DIP switch settings.
- or
- The tamper jumper is on in the Expansion Module and the Expansion Module cover is off.



Wireless Expansion (5800 System)

In This Section

- ◆ *About Wireless Expansion*
- ◆ *Installing the 5881/5882 Receiver*
- ◆ *Installing the 5800TM Module*
- ◆ *About Jam Detection and Reporting*
- ◆ *5800 Series Transmitters*
- ◆ *Installing 5800 Series Transmitters*

About Wireless Expansion

In addition to its basic wired zones, the 250P1 control supports up to 26 wireless zones using an appropriate 5881 (5882 in Canada) type RF receiver. The actual number of zones supported depends on whether you are using a wired zone expander module.

For example: If you are using only four of the wired expansion loops, a 5881H (5882H in Canada) RF receiver could add 22 RF zones to the system, using any unused zone numbers 10–35, for a combined total of 26 wired and wireless expansion zones.

The receiver can detect signals from wireless transmitters within a nominal range of 200 feet.

RF Receiver	No. of Zones
5881L/5882L	up to 8
5881M/5882M	up to 16
5881H/5882H	up to 26

Receiver Supervision

The receiver is supervised. The following conditions will cause a Trouble report to be generated and **CHECK** and **ZONE 09** messages to be displayed:

- If communication between the panel and the receiver is interrupted.
- or**
- If no valid RF signals from at least one supervised wireless transmitter are received within 12 hours.

House Identification

If you are using a 5804BD, 5827, or 5827BD Wireless Keypad with the system, you must program a House ID Code (01–31) in field *24 to establish proper communication, and the keypad must be set to the same ID.

House ID 00 disables all wireless keypads.

Installing the 5881/5882 Receiver

RF System Installation Advisories

Follow the guidelines below when installing the RF receiver. (Disregard if the receiver is mounted in the control cabinet.)

- Place the RF receiver in a high, centrally located area for best reception.
- Do not locate the receiver or transmitters on or near metal objects. This will decrease range and/or block transmissions.
- Do not locate the receiver in an area of high RF interference (revealed by frequent or prolonged lighting of the LED in the receiver; random flicker is OK).
- The RF receiver must be at least 10 feet from any remote keypads to avoid interference from the microprocessors in those units.

Installation and Setup of the 5881/5882 Receiver

To install the receiver, take the following steps:

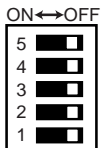

1. Set the receiver's DIP switches for device address 0, as described in its instructions (all switches to the right, the OFF position, as shown at left).
2. Mount the receiver. The RF receiver can detect signals from transmitters within a nominal range of 200 feet. Take this into consideration when determining mounting location.
3. Connect the receiver's wire harness to the control's keypad terminals (4, 5, 6, and 7). Plug the connector at the other end of the harness into the receiver.
4. Refer to the installation instructions provided with the receiver for further installation procedures regarding antenna mounting, etc.

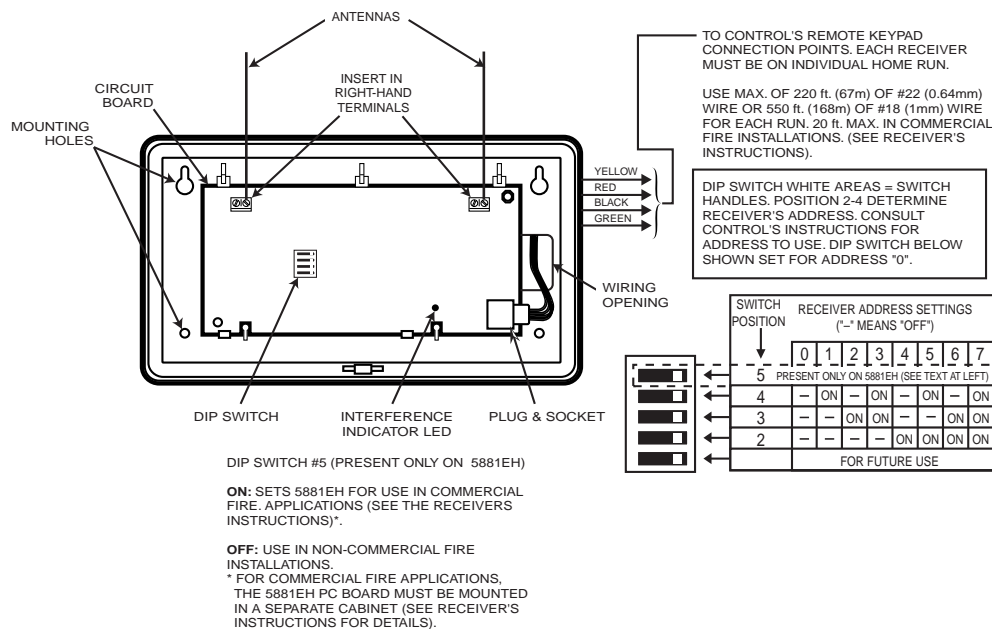

Figure 12. 5881/5882 RF Receiver (cover removed)

Installing the 5800TM Module

Installation of this module is necessary only if you are using one or more 5827BD wireless bi-directional keypads, 5804 or 5804BD transmitters (wireless keys).

Mounting the 5800TM Module

The 5800TM must be located next to the RF receiver (between one and two feet from the receiver's antennas). The 5800TM must not be installed within the control cabinet. Mount the unit using its accompanying mounting bracket.

Wiring the 5800TM Module

Connect the 5800TM to the control panel's keypad connection terminals, using the supplied connector with flying leads, as follows:

Wire	Terminal on Control
BLACK (Ground)	Terminal 4
RED (+12VDC)	Terminal 5
GREEN (Data to Control)	Terminal 6
YELLOW (Data from Control)	Terminal 7
BLUE: Not Used	

Do **NOT** cut any of the jumpers on the 5800TM when using it with the 250P1.

For additional information, refer to the 5800TM's instructions.

Jam Detection and Reporting

When field *22, option 4 (in Data Field Descriptions) is selected, a 5800 series receiver detecting a jam condition will send an **E344** (RF Receiver Jam Detect) Contact ID report to the Central Station. At the same time, a **Rcvr Jam** message will toggle with the present system message on the keypad. When the jam condition is cleared, a Restore message is sent to the CS. Entering a code and OFF will restore the keypad display. The default for this option is 0 (disabled).



Normal use of a 5827 wireless keypad may cause a false RF jam message to be displayed in systems that have been programmed for RF Jam detection.

About 5800 Series Transmitters

Enrolling Serial and Zone Numbers

5800 series transmitters have built-in serial numbers that you must "enroll" into the system using the *56 or *58 Interactive mode, or input to the control via the downloader.

5800 Series transmitters (except 5827, described separately) do not have DIP switches.

You can program each transmitter's zone number into the system in *56 or *58 mode. Some transmitters, such as the 5816 and 5817, can support more than one "zone" (referred to as loops or inputs). On the 5816, for example, the wire connection terminal block is loop 1, the reed contact is loop 2. Each loop must be assigned a different zone number.



The 5816 and 5817 transmitters do not have EOL supervision of their loop wiring. Therefore, for UL Household Burglary installations, the loop wiring may not exceed 3 feet.

For button transmitters (RF “keys”), such as the 5801, 5803, 5804, and 5804BD, you must assign a unique zone number to each individual button used on the transmitter. Each button on the transmitter also has a pre-designated loop or input number, which is automatically displayed on the keypad.

Programming an RF House ID

Programming an RF House ID (01–31) in field *24 **is necessary only if you are using 5827 or 5827BD Wireless Keypads or 5804BD Transmitters**. An RF House ID is not necessary for other 5800 Series Transmitters, and the entry should be left at 00 (default) in those cases.

The 5827 reports low-battery status as zone 00.

Transmitter Supervision

Except for some transmitters that may be carried off-premises (5802, 5802CP, 5803, 5804, 5804BD, 5827, and 5827BD), each transmitter is supervised by a check-in signal that is sent to the receiver at 70–90 minute intervals. If at least one check-in is not received from each supervised transmitter within a 12-hour period, the “missing” transmitter number(s) and the message **CHECK** will be displayed.

The supervision for a particular transmitter in the system that may also be carried off the premises (5801, 5802MN) may be turned off by enrolling it as a “UR” (unsupervised RF) type, as described later.

5800 Series Transmitters have built-in tamper protection and will annunciate as a “check” condition if covers are removed.

Transmitter Input Types

All of the transmitters described have one or more unique factory-assigned input (loop) ID codes. Each of the inputs requires its own programming zone (e.g., a 5803’s three inputs require three programming zones). See *Appendix A*.

Transmitters can be enrolled as one of the following types:

Type	Description
RF (Supervised RF)	Sends periodic check-in signals, as well as fault, restore, and low-battery signals. The transmitter must remain within the receiver’s range.
UR (Unsupervised RF)	Sends all the signals that the “RF” type does, but the control does not supervise the check-in signals. The transmitter may therefore be carried off-premises.
BR (Unsupervised Button RF)	Sends only fault signals. It will not send a low-battery signal until it is activated. The transmitter may be carried off-premises.

Transmitter Battery Life



Do not install batteries in wireless transmitters until you are ready to enroll the transmitters during system programming. After enrolling, batteries need not be removed.

Batteries in the wireless transmitters may last from 4 to 7 years, depending on the environment, usage, and the specific wireless device being used. Factors such as humidity, extreme temperatures, as well as large temperature variations may all reduce the actual battery life in a given installation. The wireless system can identify a true low-battery situation, thus allowing the dealer or user of the system time to arrange a change of battery and maintain protection for that given point within the system.

Some transmitters (e.g., 5802, 5802CP, and 5803) contain long-life but nonreplaceable batteries, and no battery installation is required. At the end of their life, the complete unit must be replaced (and a new serial number enrolled by the control).

Button-type transmitters (such as 5801, 5802, 5802CP, and 5803) should be periodically tested for battery life.

The 5802MN and 5804 Button Transmitters have replaceable batteries.

Using the Transmitter Sniffer Mode

To use the transmitter Sniffer mode, perform the following steps:

1. Enter **Installer code (4112) + # + 3** on keypad. This initiates a procedure that will verify that all transmitters have been properly programmed.
2. The keypad will display all zone numbers of wireless units programmed into the system. **Fault each transmitter in turn, causing each one to send a signal, rather than let each transmitter send an automatic supervisory signal.**

As the system receives a signal from each of the transmitters, the zone number of that transmitter will disappear from the display. The transmitters may be checked upon installation, or in an installed system.

3. After all transmitters have been checked, exit the Sniffer mode by keying 4112 (**Installer code**) + **OFF**.

NOTE: Sniffer mode does not automatically expire. You must manually exit Sniffer mode by keying [**Installer code**] + **OFF**) to return to normal operation. Sniffer mode also terminates if a user arms the system from a console or a compatible wireless keypad.



Use of any RF devices other than a wireless keypad while in Sniffer Mode may cause unpredictable results.

5800 Series Transmitters Table

Also refer to *Appendix A* for transmitter input loops/button locations.

Model	Description	Input Type and Special Notes
5801	Wireless Panic Transmitter	Enroll as "3" for RF (supervised), or "4" for UR (unsupervised). Unit has 4 pushbuttons, each with a unique input (loop) code. Each pushbutton must be assigned to a zone. Note: Input loop (button) No. 4 must always be used.
5802 5802CP	Pendant Belt Clip (Personal Emergency) Transmitters	Enroll as "5" for BR (button-type transmitter).
5802MN	Miniature Personal Emergency Trans.	Enroll as "3" for RF (supervised), or "4" for UR (unsupervised). Single pushbutton-type transmitter
5804 5804BD	Wireless Key Transmitter	Enroll as "5" for BR (button-type transmitter). Has 4 pushbuttons, each with a unique input (loop) code. Each pushbutton must be assigned to a zone. Note: All buttons must be assigned the same input type.
5806 5807 5808	Wireless Photoelectric Smoke Detectors	Enroll as "3" for RF (supervised). At the "INPUT S/N" prompt, fault the detector as follows: 1. On many detectors, you must press a special test switch (not test button) to fault the detector (see detector's instructions). Note: With some detectors, you must short two contacts to fault the detector. Disengage the detector's cover and swing it open. These contacts are on the PC board near a blue jumper (see detector's instructions). Momentarily short these contacts with a small screwdriver. Two keypad beeps will occur when the detector is faulted the first time. 2. Wait 6 to 8 seconds, then press and release the test switch (or momentarily short the contacts) again. 3 beeps will sound if the control has accepted the input code, and the enrolled input (loop) number will be displayed.
5816 5816MN	Door/Window Transmitter	Enroll as "3" for RF (supervised). Has two unique input (loop) zones: one for a wired closed-circuit contact loop, and the other for a built-in reed switch (used in conjunction with a magnet). Either or both may be used.
5817	Multi-Point Universal Transmitter	Enroll as "3" for RF (supervised). Has three unique input (loop) codes: one for a DIP switch-set "Primary" contact loop, and the others for two "Auxiliary" closed-circuit contact loops. The "Primary" loop may be set for: <ul style="list-style-type: none"> • Repeating or Single Transmission • Normally Open or Normally Closed-circuit • Slow or Fast Response • 3-Minute or No Transmission Inhibit DIP Switches: Set all DIP switches to the OFF position when enrolling the serial number. Note: All loops must be assigned the same input type.
5818	Recessed Magnetic Contact Transmitter	Enroll as "3" for RF (supervised).
5819	Shock Processor Transmitter	Enroll as "3" for RF (supervised). Has three unique input (loop) zones: one for a wired closed-circuit contact loop, one for use with inertia-type shock detectors (mounted externally), and one for a built-in reed switch (used in conjunction with a magnet).
5849 5850	Glassbreak Detector/Transmitter	Enroll as "3" for RF (supervised).
5890	PIR Detector/Transmitter	Enroll as "3" for RF (supervised). The cover must be on the unit when enrolling the serial number.

† When "enrolling" a transmitter's ID code(s), any PIR in the vicinity that is not being enrolled should be covered with a cloth, tissue, etc. to prevent activation.

Installing 5800 Series Transmitters

To be sure reception of the transmitter's signal at the proposed mounting location is adequate, perform a Go/No Go Test.

Go/No Go Test Mode

The Go/No Go Tests will verify adequate RF signal strength from the proposed transmitter location. They allow you to reorient or relocate transmitters, if necessary, before mounting the transmitters permanently.

This mode is similar to the Transmitter Test mode, except that the wireless receiver gain is reduced. This will enable you to make sure that the RF signal from each transmitter is received with sufficient signal amplitude when the system is in the normal operating mode.

1. With at least one 2-line alpha keypad (6160PL2) connected to the system, enter **4112 (Installer code) + # + 4** on the keypad.
2. After you have placed transmitters in their desired locations and have run the approximate length of wire from the sensors to the transmitter's screw terminals (if used), fault each transmitter. Do not conduct this test with your hand wrapped around the transmitter, as this will cause inaccurate results.

NOTE: On button-type transmitters whose buttons have been set to Arm AWAY, Arm STAY, or Disarm, pressing a button will take the system out of the Go/No Go Test mode and cause that action.

- a. The keypad will beep three times to indicate signal reception and display the appropriate zone number.
- b. If the keypad does not beep, reorient or move the transmitter to another location. Usually a few inches in either direction are all that is required.
3. If each transmitter produces the proper keypad response when it is faulted, you can then permanently mount each of the transmitters according to the instructions provided with them.
4. Exit the Go/No Go test mode by entering **4112 (Installer code) + OFF**.

Setting DIP Switches on the 5827 Transmitter(s)

You must set a 5827 Transmitter to the programmed House ID, using its DIP switches.

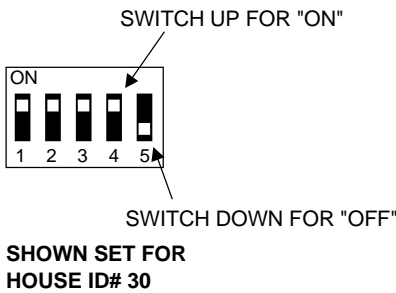

HOUSE ID	DIP SWITCH POSITION				
	1	2	3	4	5
1	-	-	-	-	UP
2	-	-	-	UP	-
3	-	-	-	UP	UP
4	-	-	UP	-	-
5	-	-	UP	-	UP
6	-	-	UP	UP	-
7	-	-	UP	UP	UP
8	-	UP	-	-	-
9	-	UP	-	-	UP
10	-	UP	-	UP	-
11	-	UP	-	UP	UP
12	-	UP	UP	-	-
13	-	UP	UP	-	UP
14	-	UP	UP	UP	-
15	-	UP	UP	UP	UP
16	UP	-	-	-	-

HOUSE ID	DIP SWITCH POSITION				
	1	2	3	4	5
17	UP	-	-	-	UP
18	UP	-	-	UP	-
19	UP	-	-	UP	UP
20	UP	-	UP	-	-
21	UP	-	UP	-	UP
22	UP	-	UP	UP	-
23	UP	-	UP	UP	UP
24	UP	UP	-	-	-
25	UP	UP	-	-	UP
26	UP	UP	-	UP	-
27	UP	UP	-	UP	UP
28	UP	UP	UP	-	-
29	UP	UP	UP	-	UP
30	UP	UP	UP	UP	-
31	UP	UP	UP	UP	UP

Relay Outputs & Powerline Carrier Devices

In This Section

- ◆ *About Relays and Powerline Carrier Devices*
- ◆ *Powerline Carrier Devices*
- ◆ *4204 and 4229 Relay Modules*
- ◆ *Programming Relay Outputs*

About Relays and Powerline Carrier Devices

Relays and Powerline Carrier devices (such as X10 brand devices) are programmable switches that can be used to perform many different functions. They can be used to turn lights on and off, control sounders, or indicate status. In this system, you must program each device as to how to act (ACTION), when to activate (START), and when to deactivate (STOP). Each of these is described in the programming procedure for *80 and *81 Interactive Modes in **Section 13: Mechanics of Programming**.

The control supports a total of 4 output devices in the following configurations:

- One 4204 Relay Module (4 relays) or 4 Powerline Carrier devices
- One 4229 Zone/Relay Module (2 relays) and 2 Powerline Carrier devices
- Up to 4 Powerline Carrier devices (4 minus the number of output relays used).



A 4204 Relay Module cannot be used if a 4219 or 4229 is already being used, and vice versa.

The 4204 and 4229 modules provide Form C (normally open and normally closed) contacts. Powerline Carrier devices are controlled by signals sent through the electrical wiring at the premises via a 4300 Transformer. Therefore, if you are using Powerline Carrier devices, a 4300 Transformer must be used in place of the regular system transformer.

Once a device is programmed into the system, the user sees no difference between a Powerline Carrier device and a relay output device.

In *80 and *81 Interactive modes, a series of keypad prompts will request entries for programming of the relay outputs and/or Powerline Carrier devices used in the system. Refer also to Output Relays/Powerline Carrier Devices Worksheet for *80 and *81 Interactive Modes in the separate Programming Form.

4204 and 4229 Relay Modules

Setting up the 4204 or 4229

The 4204 (**Figure 14**) or 4229 (**Figure 13**) relay module can be mounted either remotely or in the control panel. The following steps should be performed to properly set up the 4204 or 4229:

1. Connect the 4204/4229 to the control's remote keypad terminals (4 – 7), using the connector supplied with the 4204 and 4229. Use standard 4-conductor twisted cable for long wiring runs.

2. Set the 4204/4229's DIP switch for a device address of 1 (switch 2 in the OFF position and switches 3, 4, and 5 in the ON position). Switch 1 determines the unit's cover tamper response (ON = disabled, OFF = enabled).
3. Connect the desired field wiring to the unit's relay contact terminals.

Supervision

4204 and 4229 modules are supervised against removal. **CHECK** and **ZONE 09** will be displayed if a module is disconnected from the control's terminals (4, 5, 6, and 7). **CHECK** and **ZONE 09** will also be displayed if the module cover is removed and the tamper jumper is installed.

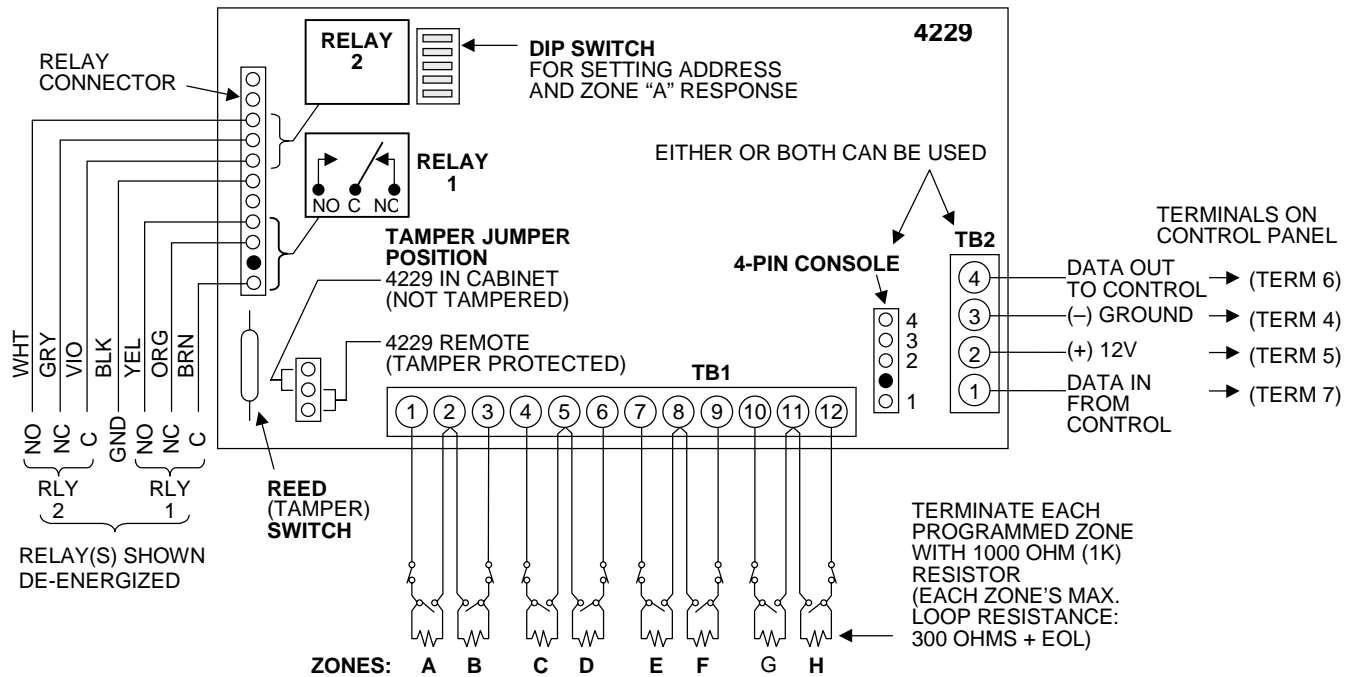

Figure 13. 4229 Connections to Control Panel

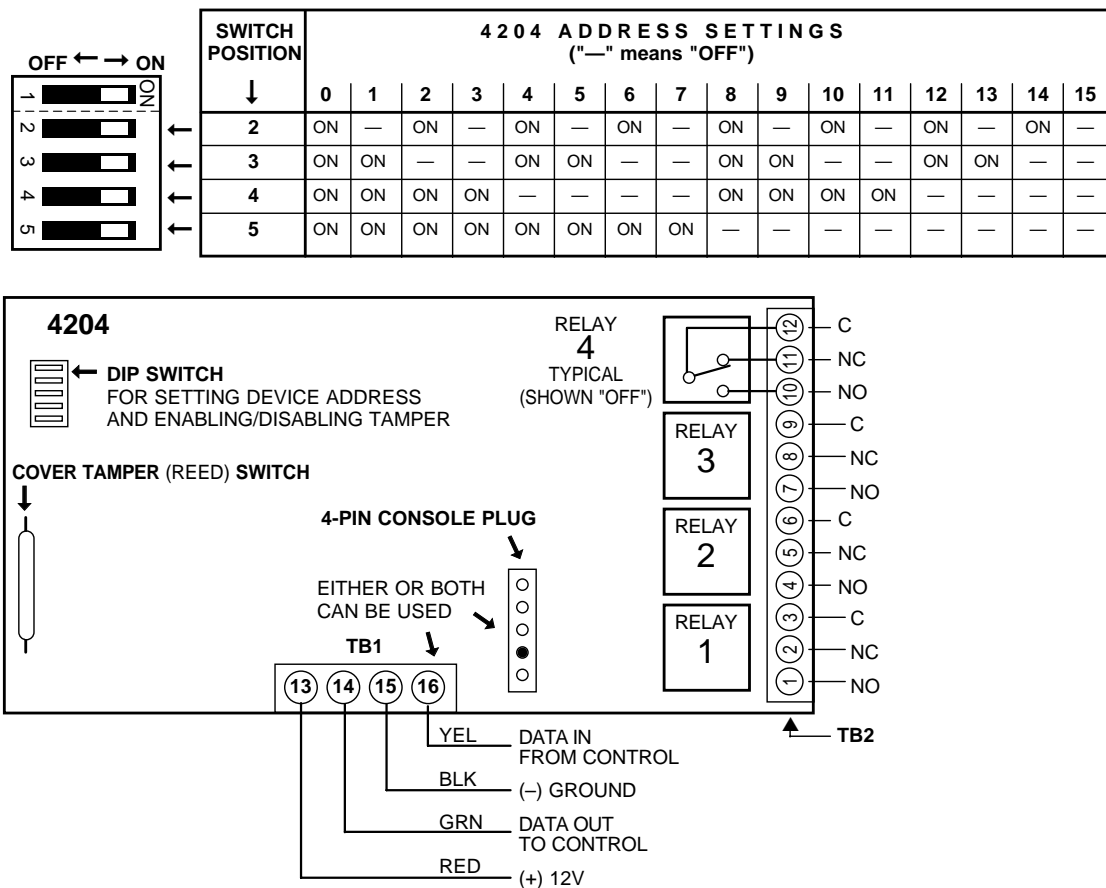

Figure 14. 4204 Connections to Control Panel

Powerline Carrier Devices

UL

Powerline Carrier devices and the 4300 Transformer are not UL Listed for fire or burglary functions, and are intended for home automation.



When using Powerline Carrier devices, you must use a 4300 Transformer **instead** of the 1321 Transformer.

The 4300 Transformer provides AC power to the control panel, and also supplies signals from the control panel through the premises AC wiring to the Powerline Carrier devices (which are plugged into AC outlets). You can then make devices plugged into Powerline Carrier devices perform various functions in response to commands you enter at the security system keypads.

Wiring Connections

To wire the Powerline Carrier Device to the control panel, perform the following steps:

1. Splice one end of a 3-conductor cable to the wire ends of the 4142TR Cable supplied with the 4300 Transformer.
2. Connect the 4142TR Cable Plug to the 9-pin connector on the control (see **Figure 22. Summary of Connections** diagram for location of the 9-pin connector).
3. Connect the other end of the 3-conductor cable to the 4300 Transformer, as indicated in the table below and in the diagram that follows.

4300 TRANSFORMER WIRE CONNECTIONS	
4300 Terminal	To Terminal on Control
1 (AC)	1 (16.5V AC in)
2 (Ground)	25 Earth Ground terminal
3 (AC)	2 (16.5V AC in)

4300 Terminal	4142TR Cable Wire
4 (Sync)	RED (Pin 5 of 9-pin connector)
5 (Data)	VIOLET (Pin 1 of 9-pin connector)
6 (Com)	WHITE (Pin 4 of 9-pin connector)

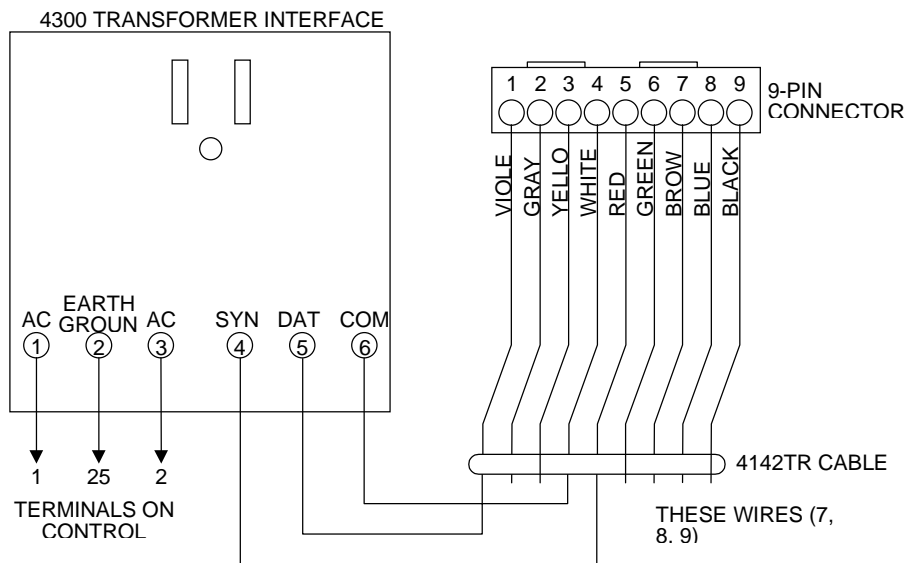

Figure 15. 4300 Transformer Wiring Connections

Programming Relay Outputs

In the 250P1, each device must be programmed as to how to act (ACTION), when to activate (START), and when to deactivate (STOP). Refer to the programming procedures for *80 and *81 interactive modes that are provided in **Section 13: Mechanics of Programming**, **Section 17: Output Device Programming**, and **Section 18: Zone Lists** for specific programming details.

4285 & 4286 VIP Module

In This Section

◆ *About the 4285 & 4286 VIP Module*

◆ *Programming the 4285/4286 VIP Module*

◆ *Installing the Phone Module*

◆ *Checking 4285/4286 VIP Module Operation*

About the 4285 & 4286 VIP Module

The 4285 or 4286 VIP Module is an add-on accessory for the 250P1 that permits access to the security system via a TouchTone phone (either on-premises or by a call-in when away). The 4286 VIP Module has the additional capability of controlling thermostat(s) and providing external speaker output.

The phone module can announce many of the same words that would normally be displayed on an alpha keypad under the same system conditions.



Only one phone module can be used in this security system.

When properly connected, the 4285/4286 VIP Module will enable the user to do the following via a TouchTone telephone:

- Receive synthesized voice messages over the phone regarding the status of the security system.
- Arm and disarm the security system and perform most other commands using the telephone keypad, with voice annunciation over the phone confirming any command that is entered.

The phone used for phone access must have touch-tone capability, though touch-tone service is not necessary. (If premises uses pulse dialing, switchable phones must be set for touch-tone temporarily before attempting phone access.)

A ***Phone Access User's Guide*** for phone access to the security system is provided with the phone module for the user of the system.

Installing the Phone Module

Mounting the 4285 or 4286 VIP Module

The phone module may be mounted in the control cabinet if space is available or, if this is not possible, on the side of the cabinet or adjacent to it.

When mounting the module outside the cabinet, use the screw holes at its rear, which will permit it to be mounted horizontally or vertically. (you may use double-sided adhesive tape if you prefer.) Wires can be brought out from the side or back (a round knockout is also available on the back).

Stick the phone module's connections label (supplied separately) to the inside of the phone module's cover, if the cover is used. If you have installed the module within the cabinet, stick the label to the inside of the control cabinet's door.



If you are also using an Audio Alarm Verification (AAV) unit, refer to **Section 11: Audio Alarm Verification (AAV) Unit** for the wiring connections required when you are using both a phone module and an AAV unit. If you are not using an AAV unit, follow the wiring connections instructions in this section for the phone module.

Wiring the Voice Interactive Phone (VIP) Module

The 4285 or 4286 VIP Module is wired between the control panel and the premises handset(s). It listens for touch-tones on the phone line and reports them to the control panel. During on-premises phone access, it powers the premise phones; during off-premises phone access, it seizes the line from the premises phones and any answering machines.

NOTE: The phone lines must be in service for the phone module to function, even when accessing the system from an on-premises phone.

1. Wire the 12V (+), 12V (-), data in, and data out points from the phone module to the control (see **Figure 17**).

Terminal On Control
12V – AUX (terminal 4)
12V + AUX (terminal 5)
DATA IN (terminal 6)
DATA OUT (terminal 7)

2. Insert the keyed connector at the other end of the connector cable into the mating header on the phone module (see diagram on next page for location of the header).
3. Connect terminals 1 through 5 on the phone module as shown in the Wiring Table below and in the 4285/4286 wiring diagram that follows.



- Use an RJ31X jack with a direct-connect cord and make all connections exactly as shown. If the leads on the direct-connect cord are too short to reach their assigned terminals, splice additional wires to them, as required.
- If no Touch-Tones are produced following access to the security system **from on-premises** (this problem may arise in rare cases), it may be necessary to reverse the wires connected to terminals 3 and 4 on the phone module **and** the wires connected to terminals 21 and 22 on the control panel. The wiring diagram shows the wiring connections that will provide proper operation in most cases.

4285/4286 WIRING TABLE

4285 Terminal	Connects to:
1. Phone In (Tip)	Terminal 21 on control panel.
2. Phone In (Ring)	Terminal 22 on control panel.
3. Phone Out (Tip)	BROWN lead from direct-connect cord.
4. Phone Out (Ring)	GRAY lead from direct-connect cord.
5. Ground	Earth ground terminal 25 on control panel.
6. Output High	Not used (4285). Spkr Hi on 4286.
7. Output Rtn	Not used (4285). Spkr Hi on 4286.

Caller ID Units

If the telephone system on the premises includes a Caller ID unit, connect the unit **directly to the Handset terminals (21 and 22) on the control**, as shown in **Figure 16. 4285/4286 VIP Module Wiring Connections** that follows.

4285/4286 VIP MODULE WIRING NOTES:

- Wire the phone module exactly as shown, using a direct-connect cord and RJ31X jack.
- If touch-tones are not heard when pressing keys following phone access to the security system via an on-premises phone, try reversing the pair of wires connected to terminals 3 and 4 on either phone module **and** the pair of wires connected to terminals 21 and 22 on the control.
- If an error signal (fast busy signal) is heard when trying to access the system via the phone, check for correct line seizure wiring, as described in note 4.
- Connection to the incoming telco line via an RJ31X jack and direct-connect cord, as shown in this diagram, is essential, even if the system is not connected to a Central Station. **The 4285 or 4286 will not function if this is not done.**

The house phone lines (gray and brown wires) must be wired to the phone module terminals, not to the control terminals. Otherwise, an error signal (fast busy signal) will occur when trying to access the system from an on-premises phone.

- If the telephone system on the premises includes a Caller ID unit, connect the unit **directly** to the Handset terminals (21 and 22) on the control, as shown below.

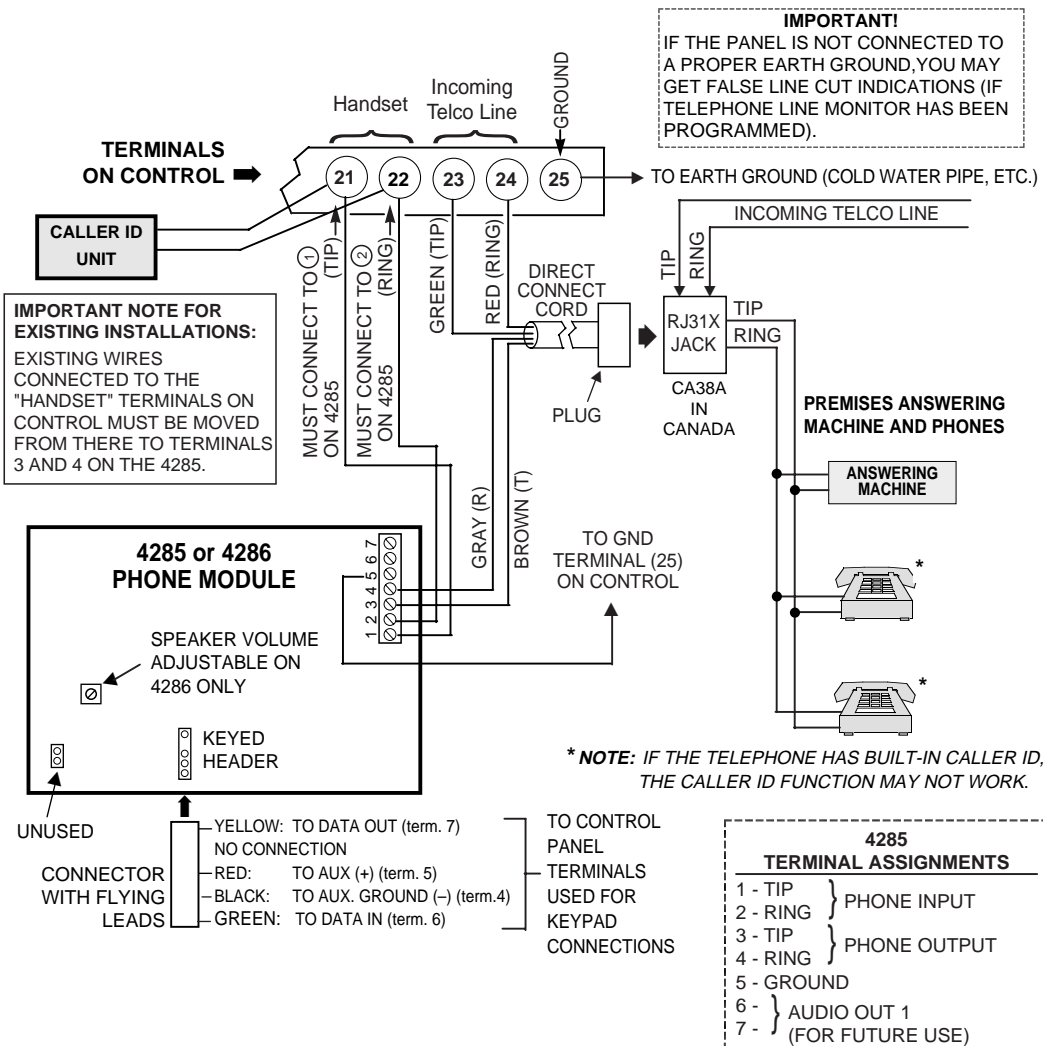

Figure 16. 4285/4286 VIP Module Wiring Connections

Programming the 4285/4286 VIP Module

You must program the system for use with the 4285 or 4286 VIP Module. This includes assigning a phone code and selecting words from the alpha vocabulary. Refer to the programming sections for specific programming details.

Checking 4285/4286 VIP Module Operation

To Check Operation From an On-Premises Phone:

1. Pick up the phone and enter the programmed 2-digit phone code. Annunciation of a system status report should automatically start. See the User's Guide accompanying the phone module for detailed information regarding the nature of the status report, if necessary.
2. During any pause in the status report, or immediately following it, key the following via the keypad on the phone:

4112 (Installer code) + 1 (OFF).

You should hear a beep on the phone and from a wired keypad. You should also hear the words, "**Disarmed...Ready to Arm**" or "**Disarmed...Not Ready to Arm**"* indicating that the command was entered successfully.

* The voice message, "**Disarmed...Not Ready to Arm**" would indicate an open zone.

3. Hang up the phone.

To Check Operation from an Off-Premises Phone:

1. Have someone dial the premises phone number, using a TouchTone phone.
 - If the phone system does not include an answering machine, 2 long tones will be heard in the caller's phone, followed by a voice prompt "**Hello, Enter Phone Code Now.**" The caller should enter the programmed 2-digit phone code.
 - If the premises phone system includes an answering machine, the 2-digit phone code should be entered during a pause at the beginning of, or during, the outgoing answering machine message. When the 2-digit phone code is entered, the caller will hear a voice prompt asking for entry of the 4-digit system code ("**Enter System Code Now**").
2. The caller should then enter the installer code (4112). As a safety feature, there is a 3-try limit in which to enter each code (phone code and system code), after which the call-in will be aborted. Also, if no keys are pressed for a period of 20 seconds, the call-in is aborted.

Annunciation of a system status report will start if both codes were entered correctly.

3. During any pause in the status report, or immediately following it, the caller should key the following via the keypad on the phone:

4112 (Installer code) + 1 (OFF).

The caller should hear a beep from the phone and a wired keypad on the premises. The caller should also hear the words "**Disarmed...Ready to Arm**" or "**Disarmed...Not Ready to Arm**"* on the phone, indicating that the command was entered successfully.

*"**Disarmed...Not Ready to Arm**" would indicate an open zone.

4. At this point, the caller can hang up the phone.
5. Verify with the caller that there was successful access to the system and that the appropriate annunciations were heard over the phone.
6. If the phone module functioned satisfactorily, unplug the AC transformer from the AC outlet.

External Sounders

In This Section

- ◆ *Compatible Sounders*
- ◆ *NFPA Requirements*
- ◆ *Sounder Connections and Power*
- ◆ *Sounder Supervision*
- ◆ *Testing the Sounder*

Compatible Sounders

The following table lists external sounders that are compatible with the 250P1:

Model	Description
ADEMCO AB-12M 10 Motorized Bell & Box	Motor bell & box. UL Grade A. 100 mA current draw.
ADEMCO 1011BE12M 10" Motorized Bell & Box	Motor bell & box. UL Listed. 100 mA current draw.
ADEMCO 702 Outdoor Siren	Self-contained 6–12 volt siren (driver built-in) and weatherproof for outdoor use. Can be wired for either a steady or warble sound.
ADEMCO 719 2-Channel Siren	Two-channel, self-contained 6-12 volt siren (driver built-in). 109dB @ 10 feet. 550mA current draw.
ADEMCO 747 Indoor Siren	Self-contained 12-volt siren (driver built-in) for indoor wall mount. 747F available for flush mounting.
ADEMCO 747UL Indoor Siren	Self-contained siren (driver built-in) for indoor wall mount. UL Listed.
ADEMCO 744 Siren Driver	6 jumper-selected sound outputs. Rated at 119dB with use of an 8-ohm 30-watt speaker.
ADEMCO 745X3 Voice Siren Driver	Voice siren driver with English, Spanish, and French voice messages. Separate messages for fire and burglary. Use with 8-ohm speaker. UL Listed.
ADEMCO 705–820, 5-inch Round Speaker	15-watt, 8-ohm speaker.
ADEMCO 713 Speaker	40-watt, 8-ohm, indoor/outdoor speaker.
System Sensor PA400B (beige)/PA400R (red) Indoor Piezo Sounder	Indoor piezo sounder (red or beige) rated at 90dB @ 10 feet.

- For UL installations, use only UL Listed sounding devices mounted indoors.

NFPA Requirements

The 250P1 complies with NFPA requirements for temporal pulse sounding of fire notification appliances.

Temporal pulse sounding for a fire alarm consists of the following:
 3 pulses – pause – 3 pulses – pause – 3 pulses . . .

Sounder Connections and Power

The 250P1 provides a 12VDC output, which can power external alarm sounders (bells or sirens; see table of compatible sounders on previous page). This output will activate a sounder when an alarm occurs.

Make connections to alarm output terminals 3 (+) and 4 (-). See **Figure 17** below.

UL

The total current drawn from the alarm output and the auxiliary power output, combined, cannot exceed 700mA. In addition, the sounding device must be a UL Listed audible signal appliance rated to operate in a 10.2-13.8VDC range. Example: Wheelock Signals Inc. siren model 34T-12 (provides 85dBA for NFPA 74 and Standard 985).

Non-UL Installations

The total current drawn from this output cannot exceed 2 amps. A battery must be installed because the battery supplies this current.



Going beyond the limits indicated (2 amps) will overload the power supply, or may cause the electronic circuit protecting the sounder output to trip.

Sounder Supervision

The 250P1 contains a sounder (Bell) supervision option. To activate the Bell supervision option:

1. Cut the red Bell Supervision Jumper located above terminals 2 and 3 on the control board. See **Figure 18**.
2. Connect a 2k ohm resistor across the terminals of the **last** sounding device.

Testing the Sounder

After you install the sounder, test the security system carefully, as follows:

1. Connect the battery wires from the control board to the battery, observing correct polarity.
2. Enter the Installer code (4112) and press the TEST (5) key on the keypad.
The external sounder should sound for 1 second if the sounder is working and proper connections have been made. Note that if the backup battery is discharged, the sounder will not turn on.
3. To turn off the Test mode, enter the Installer code (4112) and press the OFF key.
4. Disconnect the battery wires from the battery terminals.
5. Unplug the AC transformer from the AC outlet.

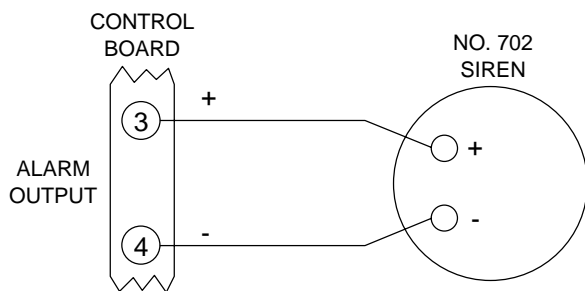

Figure 17. Typical Sounder Wiring

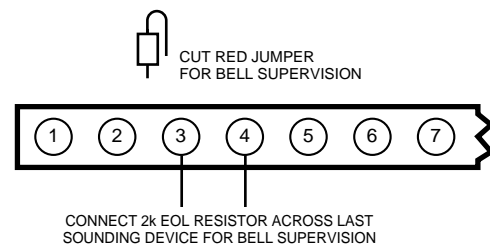

Figure 18. Bell Supervision Wiring

Long Range Radio

In This Section

◆ *About Long Range Radio*

◆ *Dynamic Signaling Feature*

◆ *Wiring Connections*

About Long Range Radio

If output to Long Range Radio is selected, all messages that are programmed to go to the primary telephone line receiver will also be sent to the 7720PLUS or 7820 Long Range Radio. These messages will be in Contact ID format (not affected by entry in field *48).

UL

For UL installations, Long Range Radio must be disabled (*29 = 0).

The data line is supervised, as well as certain functions in the radio. If communication is lost or a trouble develops, an attempt will be made to send a message via both radio and telephone to the Central Station.

For complete information, see the manual that accompanies the radio.

Wiring Connections

Connect the data in/data out terminals and voltage input terminals of the No. 7720PLUS or 7820 Long Range Radio to the control's keypad connection points, terminals 4, 5, 6, and 7, as shown below.

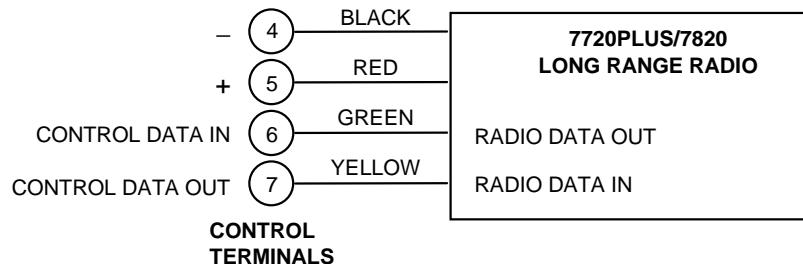

Figure 19. Long Range Radio Connections

Dynamic Signaling Feature

This 250P1 control panel features **Dynamic Signaling Delay (DSD)** and **Dynamic Signaling Priority (DSP)** message reporting when Long Range Radio is used. These message outputs are accessed through data field ✖79. The Dynamic Signaling feature is designed to reduce the number of redundant reports sent to the Central Station.

The features are described as follows:

- **Dynamic Signaling Delay (DSD)**

You can select the time the panel should wait for acknowledgment from the first reporting destination before it attempts to send a message to the second destination. Delays can be selected from 0 to 225 seconds, in 15-second increments. This choice is made by the first entry in field ✖79. *This delay is applicable to each individual message.*

- **Dynamic Signaling Priority (DSP)**

You can select the initial reporting destination for messages, Primary Dialer or Long Range Radio. This choice is made by the second entry in field ✖79.

The chart below provides a concise explanation of how the Dynamic signaling feature functions.

If Priority (✖79, 2nd entry) is...	And message is...	Then...
Primary Phone No. ("0" entered)	Acknowledged before delay expires	Message is removed from queue and no message is sent to LRR
	Not acknowledged before delay expires	Message is sent to both the Primary Phone No. and LRR
Long Range Radio ("1" entered)	Acknowledged before delay expires	Message is removed from queue and no message is sent to Primary Phone No.
	Not acknowledged before delay expires	Message is sent to both the Primary Phone No. and LRR



You must enable field ✖29, OUTPUT TO LONG RANGE RADIO, if this feature is to function.

Audio Alarm Verification (AAV) Unit

In This Section

◆ *About Audio Alarm Verification*

◆ *Wiring Connections*

About Audio Alarm Verification

An Audio Alarm Verification (AAV) module, such as the Eagle 1250, is an add-on accessory that permits voice dialog between an operator at a Central Station and a person at the alarm installation, for the purpose of alarm verification.



To enable the AAV feature, enter option “4” in field ★91 Option Selection (AAV), select Contact ID report format for the primary phone number, and program alarm reports for the primary phone number.

UL

The AAV option cannot be used in UL installations.

After all messages have been sent during a reporting session to the primary phone number, the control will trigger the AAV if at least one of the messages was an Alarm report. The control will send a listen-in to follow message (Contact ID event code 606), which signals the 685 to hold the phone connection for 1 minute.

Once the digital message is “kissed off,” the control will give up the phone line to the AAV module, without breaking connection with the Central Station. At this time, all sirens and all continuous keypad sounds will be shut off.



You must connect a 4204 or 4229 Relay Module when using an AAV unit. Do not use relay output number 1 for any other function.

Wiring Connections

The AAV is triggered by a 4204 or 4229 relay module, as shown in the AAV connection diagrams that follow (one diagram for connections when a 4285/4286 VIP Module is used, the other when the 4285/4286 VIP Module is not used).

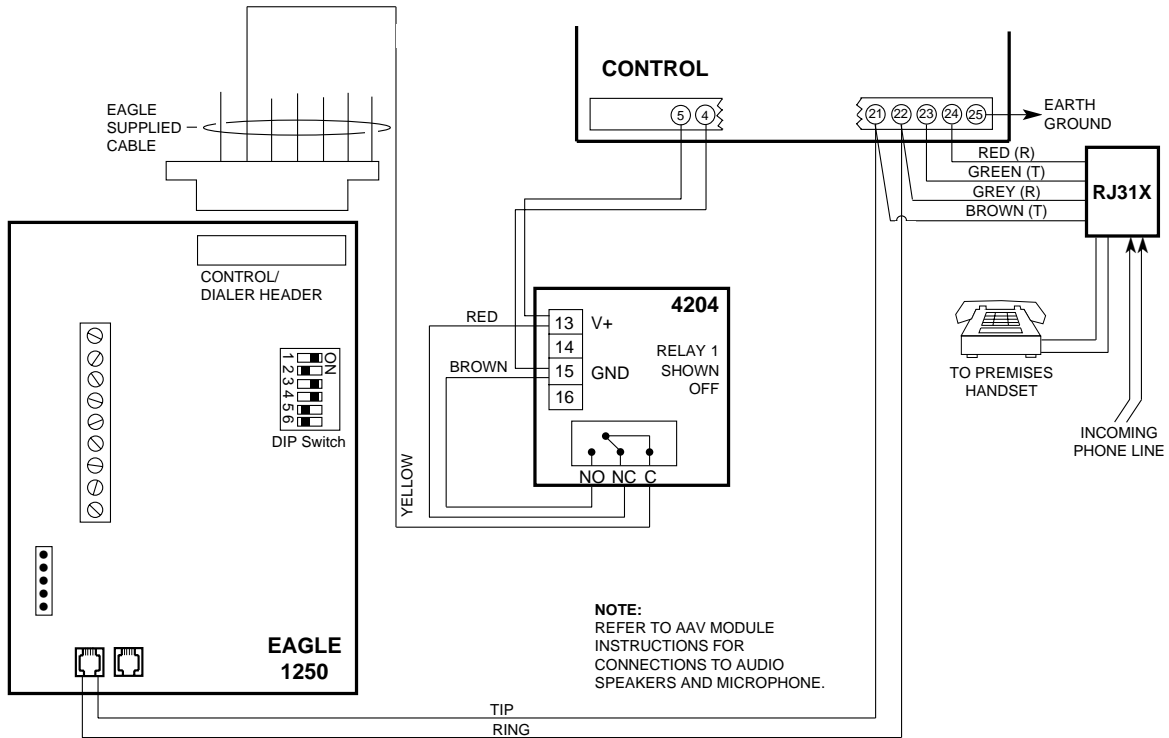

Figure 20. Connection of AAV Unit When Not Using a 4285/4286 VIP Module

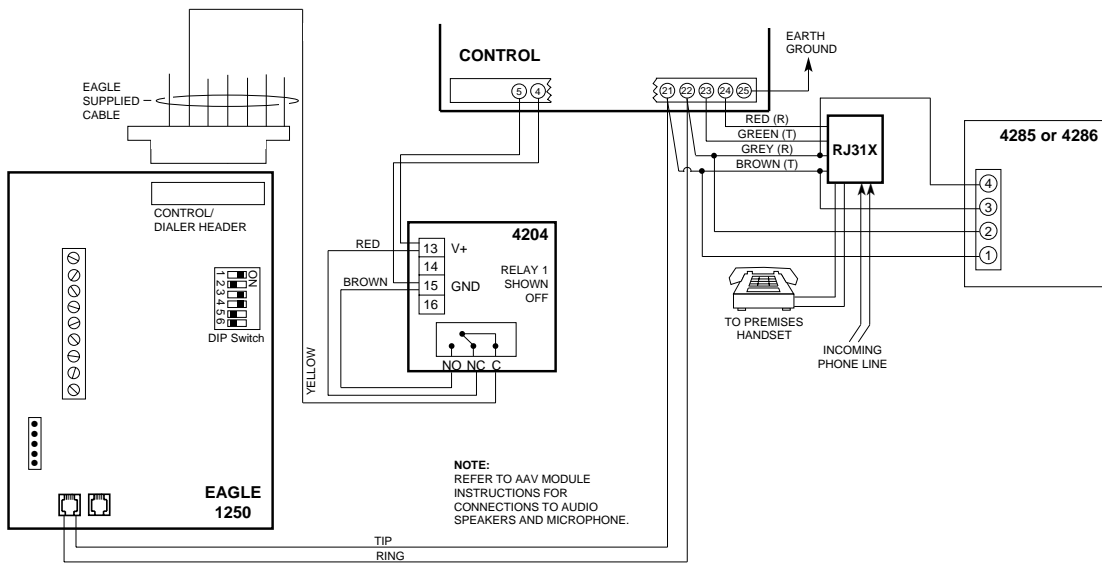

Figure 21. Connection of AAV Unit When Also Using a 4285 or 4286 VIP Module

Final Power-Up

In This Section

◆ *Earth Ground Connections*

◆ *Connecting the Backup Battery*

◆ *AC Power-Up*

◆ *Battery Tests*

Earth Ground Connections

The designated earth ground terminal (25) must be terminated in a good earth ground for the lightning transient protective devices in this product to be effective. It also must be grounded to enable the telephone line fault indicator to work properly. The following are examples of good earth grounds available at most installations:

Metal Cold Water Pipe: Use a noncorrosive metal strap (copper is recommended) firmly secured to the pipe to which the ground lead is electrically connected and secured.

AC Power Outlet Ground: Available from 3-prong, 120VAC power outlets only. To test the integrity of the ground terminal, use a 3-wire circuit tester with neon lamp indicators, such as the UL Listed Ideal Model 61-035, or equivalent, available at most electrical supply stores.

AC Power-Up

To turn on AC power, perform the following steps:

1. Plug the 1321 or 4300 Transformer into a 24-hour, unswitched 120VAC outlet.

Following power-up, one of the following will be displayed: **AC**, **dI** (disabled); **BUSY STANDBY** (alpha keypads); or **NOT READY** (fixed-word keypads). The green POWER LED (or READY LED on some keypads) should light.

2. After approximately 1 minute, the initial displays will revert to **DISARMED...READY TO ARM** for alpha keypads, or **READY** for fixed-word keypads (if there are no faulted zones). This 1-minute delay allows PIRs, etc. to stabilize.

To bypass this delay, press: # + 0.

Connecting the Backup Battery

In the event of an AC power loss, the control panel is supported by a backup, rechargeable Sealed Lead Acid battery. The minimum battery size recommended is the No. 467 (12V, 4AH) battery. See paragraph titled, *Calculating the Battery Size Needed* below. The battery is installed in the control cabinet.

The standby battery is automatically tested every 4 hours, beginning 4 hours after exiting Programming mode. In addition, entry into the Test mode will cause a battery test to be initiated.

Calculating the Battery Size Needed

Determine the total device current draw after filling in the Auxiliary Device Current Draw Worksheet that follows. To this figure add the 100mA that is drawn by the control panel itself. Then, to determine the battery size needed, use the following formula:

Total Current Drawn* x Number of hours standby wanted = Battery Ampere/Hours.

* Convert mA figure to decimal Amps (see example).

Example: If total auxiliary device current drain is 450mA, add 100mA for the control panel, for a total of 550mA (0.55 amps); if 24-hour standby is wanted, the calculation will be:

0.55A x 24 hours = 13.2 Ampere/Hour battery needed.

In this example, two 7 Amp/Hr batteries (connected in parallel) must be used.

Table 1. AUXILIARY DEVICE CURRENT DRAW WORKSHEET

DEVICE	CURRENT	# UNITS	TOTAL CURRENT
6148PL2 Keypad	30ma Standby / 50mA Alarm		
6150PL2 Keypad	40ma Standby / 100mA Alarm		
6150RFPL2 Keypad	40ma Standby / 100mA Alarm		
6160PL2 Keypad	40ma Standby / 130mA Alarm		
5881/5882 RF Receiver	35mA		
4219 Zone Expander	35mA		
4204 Relay Unit	15/180mA‡		
4229 Zone Expander/Relay Unit	35/100mA‡		
4285 VIP Module	160mA		
4286 VIP Module	300mA		
TOTAL =			
(Current available from Aux. terminals = 600mA max.)**			

* If you are using hardwire devices such as PIRs, refer to the specifications for that particular unit's current draw.

** In UL installations, maximum current draw from the Auxiliary Output and the Alarm Output **combined** must not exceed 700mA (600mA max from Auxiliary Output).

‡ Figures are for relays de-energized (OFF)/relays energized (ON).

Making the Battery Connections

1. Use the battery standby formula (above) to select the appropriate battery for the installation.



Do not connect the battery until all devices have been wired to the control.

2. Attach the red and black wires on the battery connector cable as follows:

- Red to the positive (+) battery tab on the control board
- Black to the negative (-) battery tab on the control board.

Refer to **Figure 22. 250P1 Summary of Connections** (SOC) diagram for location of the (+) and (-) battery tabs on the control board.

3. Attach the red and black wires at the other end of the battery connector cable as follows:

- Red to the positive (+) terminal on the battery
- Black to the negative (-) terminal on the battery.

Battery Tests

The battery is periodically tested automatically (approximately every four hours), and if it cannot sustain a load, a **LOW BATTERY** message is displayed and, if so programmed, will be reported to the Central Station. In addition, the connection to the battery is checked every 3 minutes (a CSFM requirement). If there is no battery detected, or a low-battery condition is detected, a **LOW BATTERY** message is displayed and a report is sent to the Central Station.

Mechanics of Programming

In This Section

- ◆ *About Programming*
- ◆ *Entering Program Mode*
- ◆ *Programming a Data Field*
- ◆ *Reviewing a Data Field/Erasing an Entry*
- ◆ *Interactive Mode Programming*
- ◆ *Loading Factory Defaults*
- ◆ *Programming System Setup Fields*
- ◆ *Exiting the Programming Mode*

About Programming

Characteristics for each installation are stored in nonremovable, electrically erasable, non-volatile EEPROM memory. These must be programmed for the particular installation to establish its specific alarm and reporting features.



If RF zones or wired expansion will be used, the following program fields **must be** programmed before doing any zone programming:

- *22 RF SYSTEM
- *25 WIRED ZONE EXPANSION

It is possible to program the system at any time, even at the installer's premises prior to the actual installation. Simply apply power temporarily to the control and then program the unit as desired.



You cannot enter the Programming mode unless the security system is disarmed.

There are two programming modes: Data Field Programming and Interactive (Menu) mode programming. Data Field Programming is used for setting various system options. Interactive Programming is used for programming zone information, programming relay outputs, and enrolling transmitter serial numbers.



To program the system, you must use a 6160PL2 (2-line alpha keypad) connected to the keypad terminals on the control (4, 5, 6, and 7). **Also, the security system must be disarmed.** The alpha keypad need not remain in the system after programming.

Programming can also be performed remotely from the installer's office/home, using an IBM personal computer, a modem, and COMPASS downloading software. See **Section 21: Remote Programming and Control (Downloading)**.

Entering Program Mode

You may use one of the following methods:

- a) Press [*] and [#] keys at the same time within 50 seconds after power is applied to the control; or
- b) After power-up, enter **4 1 1 2 (Installer code) + 8 0 0**.

This method is disabled if you exit the Program mode using *98 instead of *99. See the paragraph titled, **Exiting the Program Mode**, later in this section.

If a different Installer code is subsequently programmed, use it instead of 4112 to gain access to the Programming mode.

When you enter the Program mode, data field *20 will be displayed (this is the first data field in the system). The system will now accept entries for field *20.

Programming a Data Field

1. Press [*] + [Field No.] (for example, *21), then make the required entry.
2. When you have completely programmed a data field, the keypad will beep three times and then automatically display the next data field in sequence. To go to a different field, press [*] plus the desired field number.
3. If the number of digits that you need to enter in a data field is less than the maximum digits available (for example, the phone number field), enter the desired data, then press [*] and the next data field number to be programmed.
4. If you try to enter a non-existent field, the keypad will display **EE** or **ENTRY ERROR**. Simply re-enter [*] plus a valid field number.

Reviewing a Data Field/Erasing an Entry

Press [#] + [Field No.]. Data will be displayed for that field number. **No changes will be accepted in this mode.**

To delete an entry in a field, press [*] + [Field No.] + [*] (applies only to fields *40 to *45, *53, and *94).

Interactive Mode Programming (*56, *58, *80, through *83 and *86)

Typical prompt displayed during Interactive mode programming:

Enter Zn Num. (00 = Quit) 01
--

Zone Number ↑

Press [*] + [Interactive Mode No.] (for example, *56). The alpha keypad will display the first of a series of prompts requesting entries.

A detailed procedure (with displays of prompts) is provided in later sections of this manual.

Interactive Mode	Used to Program
*56 Zone Programming	Zone characteristics, report codes, alpha descriptors and serial numbers
*58 Expert Mode Programming	5800 Series Transmitter serial numbers
*80 Relay Programming	4229 or 4204 Relay modules, or Powerline Carrier devices
*81 Zone List Programming	Zone lists for relay/powerline carrier, cross zone activation, and NIGHT-STAY Zones
*82 Alpha Programming	Zone alpha descriptors
*83 Function Key Prgrmg.	Four Function Keys with 12 options
*86 Spcl Fnctn Prgrmg.	Four Function Keys for specific operations

Loading Factory Defaults

To load the factory defaults, enter the Programming mode, press *97, then exit the Programming mode.



Do not press *97 to load defaults if any programming has been done previously—data already programmed into the system will be changed!

*96 resets all the subscriber account numbers and CSID in preparation for an initial download.

Programming System Setup Fields

The following program fields **must be** programmed before doing any zone programming:

*22 **RF SYSTEM**

Enter **1** if 5881/5882 RF Receiver is being used; enter **0** if no receiver is being used. Default is **0** (none).

*25 **WIRED ZONE EXPANSION**

Use this field to select the type of expansion unit being used, as follows:
0 = none; 1 = 4219; 2 = 4229; 3 = 4204. Default is **0**.

Exiting the Programming Mode

*99 allows re-entry into the Program mode using **[Installer Code] + 8 0 0**.

*98 prevents re-entry into the Programming mode using the Installer code.

Zone Response Type Definitions

In This Section

◆ Zone Type Definitions

Zone Type Definitions

You must assign a zone type to each zone, which defines the way in which the system responds to faults in that zone. Zone types are defined below.

Type 00 Program a zone with this zone type if the zone is not used.
Zone Not Used

Type 01 This zone type provides Exit and Entry Delays whenever the zone is faulted if the control panel is armed in the AWAY, STAY, or NIGHT-STAY mode. When the panel is armed in the INSTANT or MAXIMUM mode, no Entry Delay is provided. Entry Delay #1 is programmable from 30-240 seconds.
Entry/Exit Burglary

Exit Delay begins whenever the control is armed, regardless of the arming mode selected, and is independently programmable from 30-240 seconds (field ★34).

This zone type is usually assigned to sensors or contacts on doors through which primary entry and exit will take place.

The 250P1 will annunciate faster beeps during the last 10 seconds of exit delay.

Type 02 This zone type provides a secondary Entry Delay whenever the zone is faulted if the panel is armed in the AWAY, STAY, or NIGHT-STAY modes. When the panel is armed in the INSTANT or MAXIMUM mode, no Entry Delay is provided. Entry Delay #2 is programmable from 30-240 seconds.
Entry/Exit Burglary

The programmed Exit Delay (field ★34) begins whenever the control is armed, regardless of the arming mode selected.

This zone type is usually assigned to sensors or contacts on doors through which secondary entry and exit will take place, and where more time might be needed to get to and from the keypad (typically used for a garage, loading dock, or basement door).

The 250P1 will annunciate faster beeps during the last 10 seconds of exit delay.

Type 03 This zone type gives an instant alarm if the zone is faulted when the panel is armed in the AWAY, STAY, INSTANT, NIGHT-STAY, or MAXIMUM mode. This zone type is usually assigned to all sensors or contacts on exterior doors and windows.
Perimeter Burglary

- Type 04 Interior Follower** This zone type gives a delayed alarm (using the programmed entry/exit time) if the entry/exit zone is faulted first. Otherwise this zone type gives an instant alarm. This zone type is active when the panel is armed in the AWAY and MAXIMUM modes. **This zone type is bypassed automatically when the panel is armed in the STAY or INSTANT mode.** If the panel is armed NIGHT-STAY, this zone type will **not** be bypassed if it is on the NIGHT-STAY Zone List 05. This zone type is usually assigned to a zone covering an area such as a foyer, lobby, or hallway through which one must pass upon entry (after faulting the entry/exit zone to reach the keypad to disarm the system).
- Because this zone type is designed to provide an instant alarm if the entry/exit zone is not violated first, it will protect an area in the event an intruder hides on the premises before the system is armed, or gains access to the premises through an unprotected area.
- Type 05 Trouble by Day/ Alarm by Night** This zone type will give an instant alarm if faulted when armed in the AWAY, STAY, INSTANT or MAXIMUM (night) mode. During the disarmed state (day), the system will provide a latched trouble sounding from the keypad (and a Central Station report, if desired). This zone type is usually assigned to a zone that contains a foil-protected door or window (such as in a store), or to a zone covering a sensitive area such as a stock room, drug supply room, etc. This zone type can also be used on a sensor or contact in an area where immediate notification of an entry is desired.
- Type 06 24-hour Silent Alarm** This zone type sends a report to the Central Station but provides no keypad display or sounding. This zone type is usually assigned to a zone containing an emergency button.
- Type 07 24-hour Audible Alarm** This zone type sends a report to the Central Station and provides an alarm sound at the keypad, as well as an audible external alarm. This zone type is usually assigned to a zone that has an emergency button.
- Type 08 24-hour Auxiliary Alarm** This zone type sends a report to Central Station and provides an alarm sound at the keypad. **(No bell output is provided).** This zone type is usually assigned to a zone containing a button for use in personal emergencies, or to a zone containing monitoring devices such as water or temperature sensors.
- Type 09 Supervised Fire (With Verification on Zone 1)** This zone type provides a fire alarm on short circuit and a trouble condition on open-circuit. The bell output will pulse when this zone type is alarmed. This zone type is always active and cannot be bypassed. **This zone type can be assigned to a hardwired zone, any zone in a wired zone Expansion Module, or wireless zones.** When used with zone 1 on the panel, 2-wire smoke detectors can be used.
- NOTE:** Only hardwired zone 1 can be programmed as a fire zone in UL installations. However, any wireless zone can be used as a fire zone.

- Type 10 Interior w/Delay** This zone type gives Entry Delay (using the programmed entry time), if tripped when the panel is armed in the AWAY mode. Entry Delay begins whenever sensors in this zone are violated, regardless of whether or not an Entry/exit Delay zone was tripped first. *No Entry Delay* is provided if tripped when the panel is armed in the MAXIMUM mode. *Exit Delay* is present for *any* arming mode. **This zone type is bypassed when the panel is armed in the STAY or INSTANT mode.** If the panel is armed NIGHT-STAY, this zone type will **not** be bypassed if it is on the NIGHT-STAY Zone List 05.
- Type 12 24 Hour Monitor** This zone type is a dynamic monitor of the fault/trouble of a zone. In the case of a cross/open, the message, "***ALARM*-24 Hr. Non-Burg. -#XXX** " (where XXX is the zone number) will be sent to the Central Station. The alarm keypad will display a fault message indicating the appropriate zone. Upon restoration of the zone, the message, "***RESTORE*-24 Hr. Non-Burg. -#XXX** " will be sent to the Central Station. The fault message will automatically disappear from the keypad. The zone restores dynamically, therefore a code + off is not needed to reset the zone. Faults of this zone type are independent of the system, and can exist at the time of arming without interference.
- Type 20 Arm-STAY** This is a special-purpose zone type, used with 5800 Series Wireless Pushbutton units, which will result in arming the system in the STAY mode when the zone is activated. Pushbutton units send the zone number as a user number to the Central Station when arming or disarming.
- Type 21 Arm-AWAY** This is a special-purpose zone type, used with 5800 Series Wireless Pushbutton units, which will result in arming the system in the AWAY mode when the zone is activated. Pushbutton units send the zone number as a user number to the Central Station when arming or disarming.
- Type 22 Disarm** This is a special-purpose zone type, used with 5800 Series Wireless Pushbutton units, which will result in disarming the system when the zone is activated.
- Type 23 No Alarm Response** This zone type can be used on a zone when an output relay action is desired, but with no accompanying alarm (e.g., lobby door access).
- Type 24 Silent Burglary** This zone type provides an instant alarm, with **no** audible indication at any keypad or external sounder, if the zone is faulted when the system is armed in the AWAY, STAY, INSTANT, or MAXIMUM mode. This zone type is usually assigned to all sensors or contacts on exterior doors and windows where bells and/or sirens are NOT desired. A report is sent to the Central Station.



All of the zone types described are available for the wireless portion of the system, if used.

The way any particular zone type reacts to a fault is altered if that zone is included in Zone List 04, the Cross Zoning List. See **Section 18. Zone Lists**.

Data Field Descriptions

In This Section

◆ Descriptions of System Data Fields

Descriptions of System Data Fields

NOTE: The blank programming form should be used to record the data for this installation. **Defaults (where applicable) are indicated in text.**

The following pages list all data fields in the 250P1 in numerical order. If you have performed the programming instructions that were included with the installation of each of the peripheral devices covered in previous sections, this table will simply serve as a reference for all data fields in the system. If you have decided to program all the data fields in the system at one time (and therefore did not perform the programming indicated previously in each section), you can use this listing to program all the data fields now.

- | | | | | | | |
|-----|--|--|---|---|---|---|
| *20 | INSTALLER CODE | <table border="1" style="display: inline-table; border-collapse: collapse;"> <tr> <td style="width: 20px; text-align: center;">4</td> <td style="width: 20px; text-align: center;">1</td> <td style="width: 20px; text-align: center;">1</td> <td style="width: 20px; text-align: center;">2</td> </tr> </table> | 4 | 1 | 1 | 2 |
| 4 | 1 | 1 | 2 | | | |
| | <p>The Installer code is used to enter the 4-digit Master security code in the normal operation mode, via the keypad. See paragraph titled “Master Code” in Section 23: System Operation for procedure.</p> <p>Enter 4 digits, 0–9.</p> | | | | | |
| *21 | QUICK ARM ENABLE | <table border="1" style="display: inline-table; border-collapse: collapse;"> <tr> <td style="width: 20px; text-align: center;">0</td> </tr> </table> | 0 | | | |
| 0 | | | | | | |
| | <p>0 = do not allow Quick Arm
1 = allow Quick Arm (the [#] key can be used instead of the security code when arming the system).</p> | | | | | |
| *22 | RF SYSTEM | <table border="1" style="display: inline-table; border-collapse: collapse;"> <tr> <td style="width: 20px; text-align: center;">0</td> </tr> </table> | 0 | | | |
| 0 | | | | | | |
| | <p>0 = no RF receiver used
1 = 5881/5882 RF receiver used without RF Jam Detection
4 = 5800 with RF Jam Detection</p> | | | | | |
| *23 | FORCED BYPASS FUNCTION | <table border="1" style="display: inline-table; border-collapse: collapse;"> <tr> <td style="width: 20px; text-align: center;">1</td> </tr> </table> | 1 | | | |
| 1 | | | | | | |
| | <p>0 = no forced bypass
1 = provide automatic bypass of all open (faulted) zones
All zones bypassed by this function will be displayed after the bypass is initiated.
UL installations: Must be 0 (no forced bypass)</p> | | | | | |
| *24 | RF HOUSE ID CODE | <table border="1" style="display: inline-table; border-collapse: collapse;"> <tr> <td style="width: 20px; text-align: center;">0</td> <td style="width: 20px; text-align: center;">0</td> </tr> </table> | 0 | 0 | | |
| 0 | 0 | | | | | |
| | <p>00 = disable all wireless keypad usage
01-31 = House ID
The House ID identifies receivers and wireless keypads.
If a 5827 or 5827BD Wireless Keypad or 5804BD Transmitter is to be used, a House ID code MUST be entered, and the keypad should be set to the same ID.</p> | | | | | |

- *25 WIRED ZONE EXPANSION** 0
- 0 = no expander module connected
 1 = 4219 connected
 2 = 4229 connected
 3 = 4204 connected
- *26 CHIME BY ZONE** 1
- 0 = no (chimes on fault of any entry/exit or perimeter zone when chime mode activated)
 1 = yes (chimes on fault of specific zones programmed in relay zone list 3 when chime mode activated)
- This option allows the installer to define the specific zones intended to chime when faulted while the system is in chime mode.
- *27 POWERLINE CARRIER DEVICE (X10) HOUSE ID** 0
- Powerline Carrier devices require a House ID. This field identifies this House ID to the control.
 If Powerline Carrier devices are used, they are selected in field * 80.
 House ID is entered in following manner:
 0 = A, 1 = B, 2 = C, 3 = D, 4 = E, 5 = F, 6 = G, 7 = H, 8 = I, 9 = J,
 # + 10 = K, # + 11 = L, # + 12 = M, # + 13 = N, # + 14 = O, # + 15 = P.
- *28 PHONE MODULE ACCESS CODE** 0 | 0
- 1-9 = first digit of access code
 [*] or [#] = second digit of access code (enter [#] +11 for “*”, or [#] +12 for “#”)
 The use of a 4285/4286 VIP Module requires a 2-digit code.
 Example: If desired access code is 7* , 7 is the first entry, and # + 11 (for *) is the second entry.
NOTE: A “0” in either digit disables the phone module.
- *29 OUTPUT TO LONG RANGE RADIO (No. 7720PLUS/7820)** 0
- If output to Long Range Radio (LRR) is selected here, all messages that are programmed to go to the primary telephone line receiver will also be sent to the 7720PLUS or 7820 radio. These messages will always be in Contact ID format (not affected by entry in field *48). The data line and certain functions in the radio are supervised. If communication is lost or a trouble develops, an attempt will be made to send a message via both radio and telephone to the Central Station.
NOTE: Normal "Trouble Restore" report (*71) is sent upon restoration of the condition.
 Entry is first digit of "Trouble Dialer" report; enter Trouble code 1-9, B (# +11), C (# +12), D (# +13), E (# +14), or F (# +15). The second digit of "Trouble Dialer" report is automatically the second digit from field *60.
 UL installations: Must be 0 (Long Range Radio disabled)
NOTE: The radio should be programmed for device address 3 on the keypad lines.

- *30 HARDWIRE SHORT DETECTION** 0
- 0 = disable; 1 = enable
- If a short occurs in any burglary zone (entry/exit 1 or 2, perimeter, interior follower, interior with delay or silent burglary) in the disarmed state, a Trouble report will be sent to the Central Station, and a **CHECK ZONE** message will be displayed on the keypad. Once a zone has been shorted, it will *NOT* restore until *ALL* faults and/or troubles have been corrected. This message can be cleared only by correcting the problem and doing two disarms (**[Code] + OFF**). If any of these zones are open, a **FAULT ZONE** message will appear on the keypad, but no message will be sent to the Central Station. The message will automatically clear when the fault is rectified. All other zone types will retain their present functions in the disarmed state, and all zone types retain their present functions in the armed state.
- *31 SINGLE ALARM SOUNDING PER ZONE** (per armed period) 1
- 0 = no limit on alarm sounding per zone
1 = limit alarm sounding to once per arming period for a given zone
UL installations: Must be 0 (no limit)
- *32 FIRE SOUNDER TIMEOUT** 0
- 0 = yes; fire sounder timeout after time programmed in field *33
1 = no fire sounder timeout; continue sounding until manually turned off
This control complies with NFPA requirements for temporal pulse sounding of fire notification appliances.
Temporal pulse sounding for a fire alarm consists of the following:
3 pulses – pause – 3 pulses – pause – 3 pulses.
- *33 ALARM BELL TIMEOUT** 1
- 0 = no timeout
1 = 4 min
2 = 8 min
3 = 12 min
4 = 16 min
- This field determines whether the external sounder will shut off after time allotted, or continue until manually turned off.
UL installations: Must be set for a minimum of 4 min (option 1)
- *34 EXIT DELAY** 2
- | | |
|---------------------|----------------------|
| 0 = 30-second delay | 4 = 120-second delay |
| 1 = 45-second delay | 5 = 180-second delay |
| 2 = 60-second delay | 6 = 240-second delay |
| 3 = 90-second delay | |
- The system will wait the time entered before it sounds an alarm if the exit door is left open after the system has been armed.
- *35 ENTRY DELAY 1** 0
- | | |
|---------------------|----------------------|
| 0 = 30-second delay | 4 = 120-second delay |
| 1 = 45-second delay | 5 = 180-second delay |
| 2 = 60-second delay | 6 = 240-second delay |
| 3 = 90-second delay | |
- The system will wait the time entered before it sounds an alarm upon entering.
UL installations: Must be set for a maximum of 30 seconds

For Fields *43 and *44:
 Enter digits 0-9;
 [#] +11=B; [#] +12=C;
 [#] +13=D; [#] +14=E;
 or [#] +15=F.

To clear entries from field, press *43* or *44*.

See separate Programming Form for examples of account number entries.

***43 PRIMARY SUBSCRIBER ACCOUNT NO.** 15 | 15 | 15 | 15 | 15 | 15 | 15 | 15 | 15 | 15
 See box at left.

***44 SECONDARY SUBSCRIBER ACCOUNT NO.** 15 | 15 | 15 | 15 | 15 | 15 | 15 | 15 | 15 | 15
 See box at left.

***45 PHONE SYSTEM SELECT** 3
 If Central Station receiver *is not* on WATS line:
 0 = pulse dial
 1 = tone dial
 If Central Station receiver *is* on WATS line:
 2 = pulse dial
 3 = tone dial

***46 REPORT FORMAT** 7 | 7
Prim. Sec.
 5 = ADEMCO Contact ID with 10-Digit Account No.
 7 = ADEMCO Contact ID with 4-Digit Account No.

For an explanation of these formats, see **Section 22: System Communication.**

NOTE: The maximum number of "Alarm" and "Alarm Restore" reports during one armed period is determined by field *93.

***47 SPLIT/DUAL REPORTING** 0
 Use options 0 - 5 when reporting to standard telephone receivers:

	TO PRIMARY PHONE NO.	TO SECONDARY PHONE NO.
0 =	All reports	None, unless primary fails; then all
1 =	Alarms, Restore, Cancel	Others
2 =	All except Open/Close, Test	Open/Close, Test
3 =	Alarms, Restore, Cancel	All
4 =	All except Open/Close, Test	All
5 =	All reports	All

***48 DIALER DELAY (BURG/FIRE) (in seconds)** 2 | 0
Burg Fire
 0 = no delay; 1 = 15; 2 = 30; 3 = 45; 4 = 60; 5 = 120
 Above options (1 through 5) provide delay of **BURGLARY ALARM** and **FIRE ALARM** reporting (except zone types 12 and 24) to the Central Station, which allows time for the subscriber to avoid a false alarm transmission. This delay does not apply to zone type 12 (24-Hour Monitor) or zone type 24 alarms (Silent Burglary), which are always sent as soon as they occur.
 UL installations: Must be set to 0 (no delay).

***49 PERIODIC TEST REPORT** 0
 0 = no test report
 1 = once every 24 hours
 2 = weekly
 3 = once every 30 days
 Test Report Code entered in field *64 is sent. Reports with Subscriber No.

***50 TEST REPORT OFFSET** 2

0 = 24 hours after exiting Program mode or download
 1 = 6 hours after exiting Program mode or download
 2 = 12 hours after exiting Program mode or download
 3 = 18 hours after exiting Program mode or download
 This is the time to first report from Programming mode or downloading.

***51 SESCOA/RADIONICS SELECT** 0

0 = Radionics (0–9, B–F reporting)
 1 = SESCOA (0–9 only reporting)
 Select 0 for all other formats.

***52 CANCEL VERIFY** 1

0 = no
 1 = yes

When enabled (1 = yes), this feature causes a message of **CANCEL ALARM** to be displayed on the LCD keypad under the following conditions:

- After the kissoff of the cancel message to the Central Station, indicating a successful transmission.
- When an alarm is successfully canceled before the Central Station received the Alarm message. (For example, if an alarm is incorrectly triggered and the user presses the 4-digit code before the dial delay time for the alarm has expired, the message will never go out to the CS.
- When the Cancel report is not enabled and the system is disarmed after an alarm has occurred.

Cancel Verify is directly dependent on *83 which programs the Special Function Keys.

The default for this option is 0 (no verification).

***53 PAGER PHONE NO.**

--	--	--	--	--	--	--	--	--	--	--	--	--	--	--	--	--	--	--	--

Enter up to 20 digits. If you enter fewer than 20 digits, exit by pressing [*] and next field number. To clear entries from this field, press *53*.

***54 PAGER REPORT OPTIONS** 0

0 = No reports sent
 1 = Open/close for all users
 3 = Open/close for users 5-16 and wireless key zones entered in zone list 6
 4 = All alarms and troubles
 5 = All alarms, troubles, and open/close for all users
 7 = All alarms, troubles, and open/close for users 5-16, and wireless key zones entered in zone list 6
 12 = Alarms and troubles for zones entered in zone list 6
 13 = Alarms and troubles for zones listed in zone list 6, open/close for all users
 15 = All alarms and troubles for zones entered in zone list 6, open/close for users 5-16, and wireless key zones entered in zone list 6

***56 ZONE PROGRAMMING MODE**

Interactive Menu mode used for programming zone attributes and report codes. Refer to **Section 16: Zone Programming** for procedure.

***58 EXPERT PROGRAMMING MODE**

Interactive Menu mode used for programming zone attributes, enrolling transmitters, and duplicating wireless keys. Refer to **Section 16: Zone Programming** for procedure.

**TO PROGRAM
SYSTEM STATUS
AND RESTORE
REPORT CODES
(*59 –*76, & *89)**

Report codes can be programmed using the interactive *56 Zone Programming mode or *58 Expert Programming mode, or codes can be entered in data fields *59 through *76 and *89.

The following guideline is to be used for programming Report codes. The actual Report code digits that you enter depend upon the particular installation, and should agree with the Central Station office receiving the signals. Use this guideline to program this entire section.

With ADEMCO Contact ID Reporting: Enter a digit in the first box to enable the zone to report. Use a different digit for each zone until you have used up available digits (1 to 15). If the number of zones exceeds the number of available digits, begin with digit 1 again. This is an “enabling” code only and is not the actual code sent to the Central Station office. Entries in the second boxes will be ignored. For System Status (non alarm) codes, enter a 1 in the first box for all the system conditions you want to send to the Central Station.

An entry of 0 in the first box will disable the report.

**SYSTEM STATUS
REPORT CODES
(*59–*68)**

***59 EXIT ERROR REPORT CODE** (See box above)

1

If the system is armed and an entry/exit or Interior zone is still open after the Exit Delay time has expired, an alarm will sound at the keypad and external sounder (keypad also displays EXIT ALARM). If the system is disarmed before the end of the Entry Delay that immediately follows, the alarm sounding will stop **and no message will be sent to the Central Station.** The keypad will display **CA** (on fixed-word keypads) or **CANCELED ALARM** (on alpha keypads).

Entry/Exit or Interior zones listed in the Cross Zone list 04, as well as interior zones listed in Night-Stay Zone List 05, will react to faults in a different manner. Refer to **Section 18. Zone Lists.**

If the system is **not** disarmed before the end of the entry delay mentioned above, and an entry/exit or interior zone is still open, an “Exit Alarm” **message will be sent to the Central Station if an Exit Error Report code is selected in this field.** The keypad will display **EA** (on fixed-word keypads) or **EXIT ALARM** (on alpha keypads), and the alarm sounding will continue until the system is disarmed (or timeout occurs).

An Exit alarm condition will also result if a fault occurs in an exit or interior zone within 2 minutes following the end of the exit delay, and an “Exit Alarm” message will be sent to the Central Station.

In the Contact ID format, the message will contain the zone number and error code 374 (“Trouble–Exit Error”) to define the alarm as an Exit Error (rather than E/E or Interior). This message will go to the primary phone number. Under any of these conditions, no “Restore” message will be sent.

If 0 is entered in this field, no special message will be sent, only the regular Alarm and Alarm Restore code for the zone.

***60 TROUBLE REPORT CODE** (See box above)

0 | 0

This will be sent if a zone goes into trouble.

***61 BYPASS REPORT CODE** (See box above)

0 | 0

This will be sent when a zone is manually bypassed.

	*62 AC LOSS REPORT CODE	0 0
	See box on previous page. Reports with subscriber number. Timing of this report is random with up to a 4-hour delay. If AC restores before the report goes out, there is no "AC Restore" report.	
	*63 LOW BAT REPORT CODE	1 0
	This will be sent when a low-battery condition exists in the system's standby battery. See box on previous page. Reports with subscriber number.	
	*64 TEST REPORT CODE	2 0
	This is sent periodically to test that the communicator and phone lines are operational (frequency of report is selected in field *49). See box on previous page. Reports with subscriber number.	
	*65 OPEN REPORT CODE	0
	This is sent upon disarming of the system. See box on previous page.	
	*66 ARM AWAY/STAY REPORT CODE	0 0
	This option allows for independent programming of Away and Stay reports. Arming the system in the MAXIMUM mode will generate an Away report, and arming the system in the INSTANT or NIGHT-STAY mode will generate a Stay report. NOTE: Open reports are not sent if the associated Closing report is not enabled.	
	*67 RF XMTR LO BAT REPORT CODE (See box on page 15-7)	3 0
	This is sent in the event that a wireless transmitter low-battery condition exists.	
	*68 CANCEL REPORT CODE (See box on page 15-7)	4 0
	This is sent upon entering the 4-digit code and pressing the special function key programmed for CANCEL (refer to *83 for programming the special function key).	
RESTORE REPORT CODES (*70-*76)	*70 ALARM RESTORE REPORT CODE (1st digit)	0
	This is sent when the zone that caused an alarm is restored to its non-faulted condition.	
	*71 TROUBLE RESTORE REPORT CODE	0 0
	See box on page 15-7. This is sent when a trouble in a zone is restored.	
	*72 BYPASS RESTORE REPORT CODE	0 0
	See box on page 15-7. This is sent when a zone that has been bypassed is unbypassed.	
	*73 AC RESTORE REPORT CODE	0 0
This is sent when AC power has been restored after an AC power outage. See box on page 15-7. Reports with subscriber number.		
*74 LOW BAT RESTORE REPORT CODE	5 0	
This is sent when a system low-battery condition is restored to normal. See box on page 15-7. Reports with subscriber number.		

**DAYLIGHT SAVING
TIME (*77-78)**

- *75 **RF XMTR LOW BATTERY RESTORE CODE** 6 | 0

See box on page 15-7. This is sent when a transmitter that previously sent in a "Low Battery" message has sent a message indicating it no longer has a low-battery condition.
- *76 **TEST RESTORE REPORT CODE** 0 | 0

This is sent when the Test mode is exited. See box on page 15-7. Reports with subscriber number. A restore code entered here will cause a "Restore" message to be sent when Test mode is exited.
- *77 **DAYLIGHT SAVING TIME START/END MONTH** 4 | 10

0 = Disabled
 1 = Jan, 2 = Feb, 3 = Mar, 4 = April...10 = Oct, 11 = Nov, 12 = Dec
 (Enter 0 - 9; # + 10 for Oct; # + 11 for Nov; # + 12 for Dec.)
- *78 **DAYLIGHT SAVING TIME START/END WEEKEND** 1 | 5

0 = disabled 4 = fourth
 1 = first 5 = last
 2 = second 6 = next to last
 3 = third 7 = third to last
- *79 **DYNAMIC SIGNALLING** 0 0

1st Entry 2nd Entry

1st Entry **Dynamic Signalling Delay (DSD):**
 0-15 times a 15-sec delay. Ex: A 1st Entry of 5 = 5 x 15 or 75 sec.
 e.g., 0 = No delay; 1 = 15 secs; 2 = 30 secs; 3 = 45 secs; etc.
 Note: If default setting (0) is not changed, the control panel will send redundant reports to both the Primary Phone No. and LRR.

2nd Entry **Dynamic Signalling Priority (DSP):**
 0 = Primary Phone No. first; 1 = Long Range Radio (LRR) first.
 Default is 0.
- *80 **OUTPUT DEVICES**

Interactive menu mode applicable only if field *25 is programmed for a 4204 or 4229, or if Powerline Carrier devices are being used.
 Refer to **Section 17: Output Device Programming** for detailed procedure.
- *81 **ZONE LISTS FOR OUTPUT DEVICES**

Interactive Menu mode applicable if *25 is programmed for a 4204 or 4229, or if Powerline Carrier devices are being used.
 Cross Zone, NIGHT-STAY, and Pager Reporting zone lists are also programmed in this field.
 Refer to **Section 18: Zone Lists** for detailed procedure.
- *82 **CUSTOM ALPHA EDITING**

Interactive Menu mode used to program zone descriptors.
 Refer to **Section 19: Alpha Descriptor Programming** for procedure.
- *83 **FUNCTION KEY PROGRAMMING**

Interactive Menu mode used to program the four alphabet function keys to perform one of 11 system operations. These operations can be programmed to be performed individually or as a series of automatically initiated commands (called macros). Refer to **Section 20: Function Key Programming**.

Special Function #1 default Alpha Descriptor is SERVICE.

***84 AUTO STAY ARMING** 0

0 = no 1 = yes

With this field enabled (1) and system armed in **AWAY (or MAXIMUM)** mode by a non-RF device, the system will automatically revert to armed **STAY (or INSTANT)** mode if no opening/closing takes place within the programmed exit delay time. An "Opening" report followed by an "Armed Stay" report will be sent to the Central Station. Any RF device that arms the system **AWAY (or MAXIMUM)** overrides this feature and the system will remain armed in the **AWAY (or MAXIMUM)** mode.

***85 CROSS ZONE TIMER (in seconds)** 0

0 = 30; 1 = 45; 2 = 60; 3 = 90; 4 = 120; 5 = 180; 6 = 240

Sets the maximum amount of time in which two cross zones (zone list 04) must be tripped in an armed system to send an Alarm message to the Central Station. If only one cross zone is tripped during this time, a "Trouble" message (report) is sent to the Central Station.

***86 SPECIAL FUNCTION PROGRAMMING**

Allows the user to program up to two special messages when activated in field *83. Refer to **Section 20: Function Key Programming**.

***87 PAGER DELAY TIMER** 3

0 = none; 1 = 1 minute; 2 = 2 minutes; 3 = 3 minutes

Field determines the delay (if any) of Alarm reports to the pager.

***88 PAGER CHARACTERS**

When programmed in field *47, reports will be sent to the pager depending upon the number selected.

--	--	--	--	--	--	--	--	--	--	--	--	--	--	--	--	--	--	--	--

This programming field (*88) allows up to 16 digits to be entered to signal a pager. For example, these optional 16 digits may be composed of the following:

- PIN number (to identify a specific pager to the paging company)
- Subscriber account number
- * (enter # + **11** to send *)
- # (enter # + **12** to send #)
- Pause (enter # + **13** to allow a 2-second pause)
- Any special character(s) the end user may decide to transmit

All 16 digits do not have to be used.

The preceding 16 digits (if any) will be followed by a 7-digit Pager Format,

which is defined as follows:

--	--	--	--	--	--	--	--

Pager Format: XXX-YYYY
where:

- XXX = 3-digit event code:
- | | |
|---------------|--------------------------|
| 911 = Alarm | 101 = Opening (disarm) |
| 811 = Trouble | 102 = Closing (arm AWAY) |

YYYY = User or zone number (depending on type of event).

For System Status and Restore reports: Do **NOT** enter report codes for conditions that are being sent to the pager only.

The first two digits must always be 00, and must be followed by the 2-digit user or zone number. Paging is enabled in the Split/Dual Reporting field *47 by entering a number greater than 5.

NOTE: Some pagers may require an additional delay (pause) to be programmed into this field in order to receive the entire message. Field *87 provides an optional pager reporting delay of 0, 1, 2, or 3 minutes for alarm messages only.

***89 EVENT LOG 80% FULL REPORT CODE** 0 | 0

If an Event Logging selection is made in field *90, a message can be sent to the Central Station receiver when the log is 80% full. If the log becomes full, a new message will overwrite the oldest message in the log.

NOTE: Aside from the selection made by the installer in field *90, all control and readout from the log is accomplished via the downloader.

***90 EVENT LOGGING** 15

- 0 = no event logging
- 1 = log Alarm/Alarm Restore
- 2 = log Trouble/Trouble Restore
- 4 = log Bypass/Bypass Restore
- 8 = log Open/Close
- x = log combination of events (add value of entries)

Example: To select "Alarm/Alarm Restore" and "Open/Close," enter **9** (1 + 8); to select all events, enter **#15**.

The default of 3 = Alarm/Alarm Restore (1) plus Trouble/Trouble Restore (2). The 250P1 system can record up to 48 events in a history log. The types of events to be logged are selectable. At any time, the downloader operator can then upload the log and view or print out all or selected categories of the log. The downloader operator can also clear the log.

The display/printout at the Central Station will show the date, time, event, and description of the occurrences. The time is calculated by an internal clock at the Central Station computer. Note that the time for any events that occur prior to a system power-down or an entry into the Programming mode cannot be calculated by the Central Station computer. The time will then appear on the log as "unknown."

NOTE: System messages are logged when any nonzero selection is made.

***91 OPTION SELECTION (Audio Alarm Verification)** 8

- 0 = not using AAV
- 4 = an Audio Alarm Verification (AAV) unit is connected to the system
- 8 = enable Exit Delay restart
- 12 = both AAV and Exit Delay Restart
- UL installations: Must be 0 (AAV disabled)

***96 INITIALIZE DOWNLOAD ID AND SUBSCRIBER ACCT. NO. FOR
DOWNLOADING**

Pressing *96 initializes the system for downloading.

***97 SET ALL PROGRAM FIELDS TO DEFAULT VALUES**

Pressing *97 automatically loads all defaults and erases any information previously programmed.

***98 EXITS PROGRAMMING MODE**

Prevents re-entry by entering **[Installer Code] + 8 + 0 + 0**

Allows re-entry only by power-up, then * and #.

***99 EXITS PROGRAMMING MODE**

Allows re-entry to Program mode by entering **[Installer Code] + 8 + 0 + 0;**
or by powering up, then entering * and #.

Zone Programming

(*56/*58 Menu Mode)

In This Section

- ◆ About Zone Programming
- ◆ *56 Zone Programming Procedures
- ◆ *58 Expert Programming Mode Procedures
- ◆ To Remove a Zone
- ◆ To Delete a Transmitter Serial Number
- ◆ To Enter and Duplicate Wireless Keys

About Zone Programming

*56 Zone Programming and *58 Expert Programming are interactive menu modes that are used to enroll 5800 Series RF Wireless Transmitter serial numbers, program zone numbers, zone types, report codes, input device types, and loop numbers (for wireless devices). *56 Zone Programming mode can also be used to enter alpha descriptors for programmed zones, however, we recommend entering descriptors in menu mode *82 (**Section 19: Alpha Descriptor Programming**) after all zone programming has been completed). Refer to the zone assignment table for *56 and *58 on the separate programming form.

*56 Zone Programming Procedures

Note: Before proceeding, you must program field *22 (RF System) and field *25 (Wired Zone Expansion) as required.

In the programming mode, press *56.

SET TO CONFIRM?
0 = NO 1 = YES 0

This display will appear upon entry into *56 mode. The default is **0** (No). If **1** (Yes) is entered, you will be prompted to confirm each transmitter after entering the serial and loop numbers (at the **XMIT TO CONFIRM** prompt later in this procedure). **We recommend that you confirm the programming of every transmitter.**

Enter Zn Num.
(00 = Quit) 10
Zone 10 entered ↑

Zone Number (Zn): Enter the zone number that you wish to program. Zone 10 has been entered as an example in display at left.

Press [*] to continue.

Zn	ZT	RC	In:	L
10	00	10	RF:	-

A summary display appears, showing the status of that zone's programming when using wireless keys.

Note: If hard-wired zones (01-06) are being programmed, the display will appear as follows.

Zn	ZT	RC	In:	RT
02	00	10	HW:	0

Refer to Response Time options on next page.

Press [*] to continue.

↓ Zone Number

10 Zone Type Perimeter	03
---------------------------	----

Zone Type ↑

Zone Type (ZT): Enter the Zone Type response (or change it, if necessary).

Each zone must be assigned to a zone type, which defines the way in which the system responds to faults in that zone.

Enter the Zone Type code (or change it, if necessary). Zone types are listed below.

Note: If 00 is entered, **Delete Zone ?** will be displayed.

- | | | |
|-------------------------------|-----------------------|----------------------|
| 00 = Not used | 06 = 24-Hr Silent | 20 = Arm-STAY |
| 01 = Entry/exit #1 | 07 = 24-Hr Audible | 21 = Arm-AWAY |
| 02 = Entry/exit #2 | 08 = 24-Hr Aux | 22 = Disarm |
| 03 = Perimeter | 09 = Fire w/Verif. | 23 = No Alarm |
| 04 = Interior Follower | 10 = Interior w/Delay | Response |
| 05 = Trouble Day/ Alarm Night | 12 = 24-Hour Monitor | 24 = Silent Burglary |

Default values for hard-wired zones 01 to 06 are:

Zone No. (Zn):	1	2	3	4	5	6
Zone Type Default:	09	01	01	03	03	04

Press [*] to continue.

10 Report Code 1st 01 2nd 00 10

Report Code (RC): Enter the report code. This consists of 2 hexadecimal digits, each in turn consisting of 2 numerical digits. For example, for a report code of "10", enter **01** and **00**. Refer to **Section 22: System Communication** for more information about report codes and report code formats.

Press [*] to continue.



Note that report codes are defaulted to 10 for use with CID reporting.

02 Response Time	1
------------------	---

Press [*] to continue.

Response Time (RT): Enter the desired response time for hard-wired zones 01-06 (zone 02 is used as an example in display at left). 0 = 10mSec, 1 = 350mSec, or 2 = 700mSec.

Default value = 1 for all zones.

Press [*] to continue.

10 INPUT TYPE	3
RF TRANS	

Enter Input Device type (In). *Used for Input Type entry.*

- 2** = AW (Aux wired zone), **3** = RF (supervised RF transmitter,
- 4** = UR (unsupervised RF transmitter), **5** = Button type RF transmitter (unsupervised).

Note: For the built-in hardwired zones, the Input Device type is automatically displayed as HW and cannot be edited.

Press [*] to continue.

10 INPUT S/N: L	L
A022-4064	1

Serial number Entry and Loop Number Entry.

Used only when enrolling wireless transmitters.

- a. Transmit two open and close sequences. If using a button-type transmitter, press and release the button twice.

OR

Manually enter the 7-digit serial number printed on the label of the transmitter, using the Alpha display keypad.

The cursor will move to the "L". You can edit the loop number, if necessary. When the loop number is acceptable, press [*].

- b. To copy the serial number previously enrolled (used when programming a transmitter with several input loops), simply press key [C].

10	INPUT S/N	L
	A022-4064	?

Note: If the [C] key is used to copy the previously enrolled serial number, the cursor will move to the Loop column (L) with the previous serial number displayed, and display a highlighted question ? mark for the loop number.

Enter the loop number and press [*].

The system will then check for a duplicate serial/loop number combination.

If a duplicate serial/loop number combination is found, the keypad will emit a single long beep, and prompt with a “?” again for a different loop entry.

10	INPUT S/N	L
	A022-4064	1

If serial/loop number combination is not a duplicate of one already in the system, a display showing the serial number and loop number entry will appear.

Press [*] to continue.

To Delete a Serial Number →

To delete an existing serial number, enter **0** in the loop number field. The serial number will change to **0**'s.

10	INPUT S/N:	L
	A000-0000	0

If **0** was entered in error, simply re-enter the loop number, and the serial number will return to the display.

Press [*] to accept.

XMIT TO CONFIRM		
PRESS * TO SKIP		

Confirmation Option: *This prompt will only appear if you answered **Yes** at the first prompt in this section on page 16-1.*

The system will enter a confirmation mode so that the operation of the actual programmed input can be confirmed. Activate the loop input or button that corresponds to this zone.

We recommend that you confirm the programming of every transmitter before proceeding to the next zone.

If Serial or Loop Numbers do not match after activating the transmitter →

If the serial/loop number combination transmitted does not match the serial and loop number entered, a display similar to the one below will appear. **If the loop number does not match, it will also be displayed.**

Keyd	A022-4063	1
Rcvd	A022-4064	1

If so, activate the transmitter's loop input or button one or more times.

If a match is still not obtained (i.e., summary display does not appear), press the [#] key twice and enter the correct loop input or, if correct, press [#] again and then enter the correct serial number.

Zn	ZT	RC In:	L
10	03	10 RF:	1s

If the serial number transmitted matches the serial number entered, the keypad will beep 3 times and a summary display will appear, showing that zone's programming. Note that an “s” indicates that a transmitter's serial number has been enrolled.

Press [*] to accept the zone information and display the **PROGRAM ALPHA?** prompt.

PROGRAM ALPHA? 0 = NO 1 = YES 0

If you want to program descriptors for zones now, enter **1** (Yes) and refer to **Section 19: Alpha Descriptor Programming** for available descriptors.

ENTER ZN NUM. (00 = QUIT) 11

If **0** (No) was entered above, the system will return you to the **ENTER ZN NUM.** prompt for the next zone.

When all zones have been programmed, enter **00** to quit.



When you have finished programming all zones, test each zone using the system's TEST mode. **Do not use the Transmitter ID Sniffer Mode for checking wireless transmitting devices**, as it will only check for transmission of one zone on a particular transmitter, NOT the zones assigned to each additional loop.

NOTE: Following the successful enrollment of each wireless device, remove **ONE** of the serial number labels from the device and affix it in the appropriate column on the ENROLLED TRANSMITTERS worksheet of the Programming Form; then enter the other information (zone number, zone type, loop number, etc.) relevant to that device.

*58 Expert Programming Mode Procedures

Enter the program mode and follow the step-by-step instructions that follow.

Note: Before proceeding, you must program field *22 (RF System) and field *25 (Wired Zone Expansion) as required.

SET TO CONFIRM? 0 = NO 1 = YES 0

Press *58. This display will appear upon entry into this mode. The default is **0** (No).

If **1** (Yes) is entered, you will be prompted to confirm each transmitter after entering the serial and loop numbers (see "XMIT TO CONFIRM" prompt below). **We recommend that you confirm the programming of every transmitter.**

Zn ZT RC IN: L 10 00 10 RF: 1

A summary screen will appear, showing zone 10's current programming or default values.

Zn ZT RC IN: L 10 - - -: -

Enter the first digit of the zone number to be programmed. In the example at the left where zone 10 is to be programmed, the first digit **1** is entered, followed by the 2nd digit **0**. The display will show dashes, as shown at left. If zone 9 was to be programmed, you would press the 0 key, then the 9 key. You must always program zones using two digits.

Use the [D] key to enter wireless keys. When the [D] key is pressed, a special prompt will be displayed which offers a series of default templates for wireless keys. Go to the paragraph on page 16-7 titled **To Enter and Duplicate Wireless Keys** for the necessary procedure.

If Serial or Loop Numbers do not match after activating the transmitter
→

If the serial/loop number combination transmitted does not match the serial and loop number entered, a display similar to the one below will appear. **If the loop number does not match, it will also be displayed.**

Keyd	A022-4063	1
Rcvd	A022-4064	1

If so, activate the transmitter's loop input or button one or more times.

If a match is still not obtained (i.e., summary display does not appear), press the [#] key twice and enter the correct loop input or, if correct, press [#] again and then enter the correct serial number.

Zn	ZT	RC	In:	L
10	03	10	RF:	1s

If the serial number transmitted matches the serial number entered, the keypad will beep 3 times and a summary display will appear, showing the programmed information for that zone.

Note that an "s" indicates that a transmitter's serial number has been enrolled.

Press [*] to go to a blank summary display for entries for the next zone.

NOTE: Following the successful enrollment of each wireless device, remove **ONE** of the serial number labels from the device and affix it in the appropriate column on the ENROLLED TRANSMITTERS worksheet of the Programming Form; then enter the other information (zone number, zone type, loop number, etc.) relevant to that device.

To Remove a Zone

To either temporarily or permanently remove a zone from the system (5800 system):

1. Enter the programming mode:

Key **[Installer Code] + 8 + 0 + 0** and press ***56**.

2. The following display will appear:

SET TO CONFIRM?
0 = NO 1 = YES 0

Enter 0 for No; 1 for Yes.

3. The following display appears:

Enter Zn Num.	
(00 = Quit)	10

Enter zone number to be removed. Example: 10

Press [*] to continue.

Zn	ZT	RC	In:	L
10	03	10	RF:	1s

This summary display will appear.

Press [*] to continue.

01	Zone Type	
	Zone Disabled	00

4. Enter **00**. This sets the zone type to **Zone Disabled**. Press [*] to continue.

Delete Zone? 0 = No, 1 = Yes 0
--

5. The next prompt will ask whether you want to delete the zone.

1 (Yes) will permanently remove the zone from the system, while **0** (No) will disable it but retain all data except the original zone type. You can then go back to this zone later and put back an active zone type to re-enable it.

A serial number that has been entered for a 5800 system will not be deleted if the zone is temporarily disabled by answering “No” to the prompt above.

If only the physical transmitter is to be removed or changed (that is; its serial number deleted, as when replacing a unit that has a nonremovable battery), it can be done in *56 Zone Programming Mode, as indicated next.

To Delete a Transmitter Serial Number

The abbreviated procedure below can be used to delete a transmitter serial number from a zone, using the *56 Mode (5800 system).

1. In the Programming mode, press *56 to enter Zone Programming mode.
2. Then enter the zone number, and press [*] repeatedly until the cursor is under the RF Input Loop (L) position. This is the specific input (loop) or button on the transmitter that has been entered for that zone.
3. Enter 0 in the loop number field.

The serial number will change to all 0's. Note that the other programmed values for that zone will not be deleted. This will allow you to reinstate a new transmitter in its place.

10 INPUT S/N:	L
A000-0000	0

If 0 was entered in error, simply re-enter the loop number, and the serial number will return to the display.

Press [*] to accept.

4. A display for the next zone number will appear. To exit, enter 00.
5. Press *99 to exit the Programming mode.

To Enter and Duplicate Wireless Keys

If the D key was previously pressed on page 16-4 to enter and duplicate 5804 and/or 5804BD wireless keys, the following screens will appear:

TEMPLATE ? 1-6 1
--

1. Enter Template number 1-6 (later in this section).
1-3 = 5804 templates; 4-6 = 5804BD templates. See the defaults provided for each template in the chart that follows these procedures.
2. Select from templates. Press [*] to display template (1 shown selected). **Note:** If necessary, press [#] to back up and re-enter template number.
3. Press [#] if you want to return to zone attributes screen.

L 01 02 03 04 T 21 22 23 28

4. When [*] is pressed, the selected template will be displayed. Top line of display represents loop numbers, bottom line represents zone type assigned for each zone.
5. Press [*] to accept template.

ENTER START ZONE
00 = QUIT 22

Example of zone ↑
suggested by the
system. This indicates
that zones 22, 23, 24,
and 25 are available.

INPUT S/N L
AXXX-XXXX -

XMIT TO CONFIRM
PRESS * TO SKIP

Keyd A022-4063 -
Rcvd A022-4064 3

6. The system will search for the highest zone number available, subtract the number of consecutive zones required for the device (four zones in the case of the 5804 and 5804BD), and display the lowest zone number of the group.

If you want to start at a different zone, enter the zone desired, and press [*].

If that zone number is displayed, the system has the required number of consecutive zones available, beginning with the zone you entered. If not, the system will again display a suggested zone that can be used.

If the required number of consecutive zones is not available at all, the system will display "00".

7. Press [*] to accept.
8. Enter the serial number of the wireless key or depress any button to transmit from the wireless key.
9. Press [*] to accept the serial number. The system will check for a duplicate number.
10. If necessary, press the [#] key to back up without saving, and re-enter the serial number.

Use the [A] key to move forward within the screen, and the [B] key to move backward.

11. If "Yes" was entered at the **SET TO CONFIRM?** prompt previously (see first prompt following entry into the *58 Expert Programming Mode on page 16-4), the display on the left will appear. Confirm serial and loop numbers by activating the wireless key.

If the serial number transmitted does not match the serial number entered, a display similar to the one at left will appear.

If it doesn't match, press any button on the transmitter once again. If a match is not obtained, press the [#] key and then enter the correct serial number (steps 8 through 10 above).

If the serial number transmitted matches the serial number entered, the keypad will beep 3 times and will return you to step 6 above to enter the starting zone for the next wireless key.

NOTE: Following the successful enrollment of each wireless device, remove **ONE** of the serial number labels from the device and affix it in the appropriate column on the ENROLLED TRANSMITTERS worksheet of the Programming Form; then enter the other information (zone number, zone type, loop number, etc.) relevant to that device.

Wireless Key Predefined Default Templates

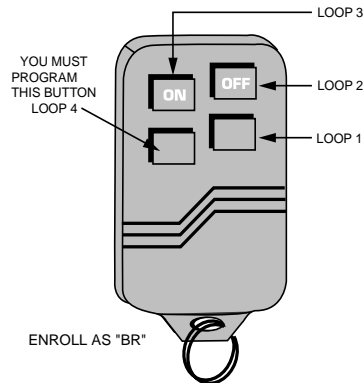

5804 Wireless Key Transmitter

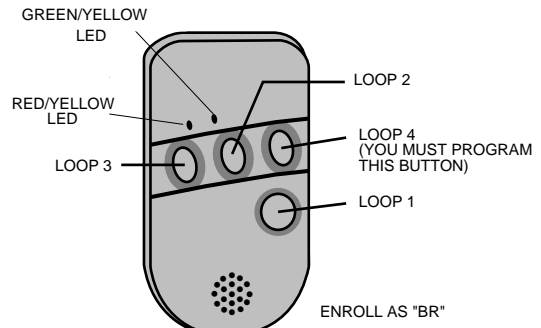

5804BD 2-Way Wireless Key Transmitter

For 5804				For 5804BD			
TEMPLATE 1	Loop	Function	Zone Type	TEMPLATE 4	Loop	Function	Zone Type
	1	No Response	23		1	No Response	23
	2	Disarm	22		2	No Response	23
	3	Arm Away	21		3	Arm Away	21
	4	No Response	23	4	Disarm	22	
TEMPLATE 2	Loop	Function	Zone Type	TEMPLATE 5	Loop	Function	Zone Type
	1	No Response	23		1	No Response	23
	2	Disarm	22		2	Arm Stay	20
	3	Arm Away	21		3	Arm Away	21
	4	Arm Stay	20	4	Disarm	22	
TEMPLATE 3	Loop	Function	Zone Type	TEMPLATE 6	Loop	Function	Zone Type
	1	24-hour Panic	07		1	24-hour Panic	07
	2	Disarm	22		2	Arm Stay	20
	3	Arm Away	21		3	Arm Away	21
	4	Arm Stay	20	4	Disarm	22	

Output Device Programming

(*80 Menu Mode)

In This Section

◆ *Programming Options Defined*

◆ *Programming Output Relays and Powerline
Carrier Devices*

Programming Options Defined

The following will help you understand the programming of Output Devices when using *80 and *81 modes. The options used to start and stop these devices are described below, followed by the actual screen prompts and available entries.



Relays and output devices are not recommended for life safety applications.

The letter(s) in parentheses after each function described below, such as (A) after ACTION, are those that appear in the various summary displays of programmed data during programming.

ACTION (A) The *action* of the device is how the device will respond when it is activated by the Start programming. There are four different choices of actions:

- ACTIVATE for 2 SECONDS and then reset.
- ACTIVATE and REMAIN ACTIVATED until stopped by some other event.
- PULSE ON and OFF until stopped by some other event.
- NO RESPONSE when the device is not used.

START (STT) The Start programming determines when and under what conditions the device will be activated. The following Start options are available:

Start by Event

1. **Event (EV)** is the condition (alarm, fault, trouble) that must occur to a zone or group of zones (a zone list) in order to activate the device. These conditions apply **only** when a zone list is used. The different choices for **event** are listed below.

- ALARM Relay activates upon any alarm in an assigned zone in the zone list.
- FAULT Relay activates upon any opening or short in an assigned zone in the zone list.
- TROUBLE Relay activates upon any trouble condition in an assigned zone in the zone list.
- NOT USED Relay action is not dependent upon one of the above events.

2. Zone List (ZL) is a group of zones to which the **event** applies in order to activate a particular device. Note that there are 3 output device-related zone lists that can be programmed in *81 Menu mode; when the selected **event** (alarm, fault or trouble) occurs in **any** zone in the selected Start zone list (1, 2, or 3), activation of the selected device will Start.

Start by Zone Type or System Operation

1. If a **System Operation**, such as *disarming* or any *fire alarm*, is to activate the device, the appropriate choice would also be entered under the **ZONE TYPE** option. **ZONE TYPE** is used independently of the "EVENT/ZONE LIST" combination.

If a **ZONE TYPE** is chosen, any zone of that response type going into alarm, trouble, or fault will cause the device to activate as selected in "ACTION." If the same **ZONE TYPE** is also chosen for the Stop programming, any zone of that type that restores will deactivate the device.

If a **System Operation** is chosen (for example, end of *exit time*), that operation will cause the device to activate as selected in **action**. The different choices for **ZONE TYPE** and **System Operation** are listed in "Programming Output Relays and Powerline Carrier Devices" later in this section, and in the Programming Form.

STOP (STP): The Stop programming determines when and under what conditions the device will be deactivated. The following options are available:

Upon Restore of a Zone List

1. Restore Zone List (ZL): If a **ZONE LIST** is used as the Stop event, the device will deactivate when **all** the zones in that list restore from a previous fault, trouble, or alarm condition. This will occur regardless of what is programmed to Start the device; therefore, a "RESTORE ZONE LIST" would normally only be used when a **ZONE LIST** is used to Start the device.

Upon a Zone Type or System Operation

1. **Zone Type/System Operation:** Instead of using a "RESTORE ZONE LIST", a specific zone (response) type or system operation action can be selected to deactivate the device.

If a specific **ZONE TYPE** is chosen, any zone of that response type that restores from a previous alarm, trouble, or fault condition will cause the device to deactivate.

If a **System Operation** is chosen, that operation will cause the device to deactivate. The different choices for **ZONE TYPE** and **System Operation** are listed in "Programming Output Relays and Powerline Carrier Devices" later in this section, and in the Programming Form.



During normal system operation, you may start any devices manually by a keypad entry of: **Code + # + 7 + n** or stop them manually by a keypad entry of: **Code + # + 8 + n**, where n = the device number to be controlled.

As a minimum, the ACTION (A) field must be programmed for this manual action to be operative.

CHOICES FOR ZONE TYPES

00 = Not Used	05 = Trouble Day/Alarm Night	10 = Interior w/Delay
01 = Entry/exit #1	06 = 24-Hr Silent	24 = Silent Burglary
02 = Entry/exit #2	07 = 24-Hr Audible	
03 = Perimeter	08 = 24-Hr Aux	
04 = Interior Follower	09 = Fire Trouble	

CHOICES FOR SYSTEM OPERATION

20 = Arming-STAY	36 = At Bell Timeout*	42 = System Battery Low
21 = Arming-AWAY	38 = Chime	43 = Comm Failure
22 = Disarming (Code + OFF)	39 = Any Fire Alarm	52 = KISSOFF
31 = End of Exit Time	40 = Bypassing	58 = Duress
32 = Start of Entry Time	41 = AC Power Failure	
33 = Any Burglary Alarm		

* or at Disarming, whichever occurs first

02 Start:	0
-----------	---

Enter **0** for any.
Press ***** to continue.

02 Stop:	Zn List	
No List		0

If a zone list will be used to Stop, or **restore**, the device action, enter the zone list number **1**, **2**, or **3** (to be programmed in *81 mode). If not used, enter **0**.

Press ***** to continue.

02 Stop:	Zn Typ	
Not Used		00

If a zone type or system operation will be used to Stop the device action, enter the appropriate 2-digit code (refer to the “**CHOICES FOR ZONE TYPES**” listed above). If not, enter **00**.

Press the ***** key to continue.

02 Stop:	0
----------	---

Enter **0** for any.
Press ***** to continue.

02	A	EV	ZL	ZT
STT	0	0	0	00

This screen again displays a summary of the current device Start (STT) programming. Press ***** to continue.

02	A	EV	ZL	ZT
STP	-	-	0	00

This screen again displays a summary of the current device Stop (STP) programming. Press ***** to continue.

02	X10 Device ?	
0 = No, 1 = Yes		00

Enter **1** if you are using a Powerline Carrier device (X10); if not, enter **0**.

The display then returns again to the first screen so that the next device number to be programmed can be entered. Enter **00** to end device programming.

Example of Output Device Programming

Assume that a lamp is to be turned on via a Powerline Carrier device (X10) when any one of 3 specific zones are faulted, or when any 24-hour auxiliary zone is faulted. Additionally, assume that you want to be able to turn off the lamp **manually** without affecting the arming status of the system.

To program this, do the following:

- In *80 Interactive mode, choose Output Device 01 and program the Action (A) to be “2” (Close and stay closed). The Event you want to *start* the Device action is a fault, so program **2** in (EV). To use Zone List 1 for the 3 specific zones, program **1** in (ZL), and program these 3 zones in *81's Zone List 1.

2. The second condition for turning on the indicator is triggering a 24-hour aux. zone (Zone Type 08). Therefore, program (ZT) as **08**.
3. To stop the Device action and turn off the lamp, you do not want to use a restore of any zone, so program a **0** for the Restore of Zone List (ZL). A manual entry of **[User Code] + # + 8 + [Device No.]** will be used to turn off. Therefore, you do not need to program a Stop event.
4. Press * to continue.
5. The system will display a summary screen for the Start programming for device 01. Press * to continue.
6. The system will display a summary screen for the Stop programming for device 01. Press * to continue.
7. The system will display the **X10?** prompt. Enter **1** for yes.
8. The **ENTER DEVICE NO.** prompt for the next zone will be displayed.

Press **00** and then [*] to exit the *80 mode.

Now use *81 Zone List mode to program the 3 specific zones in Zone List 01.



Zone type 12, 24 Hour Monitor, is a dynamic zone, which means that it faults and restores automatically, independent of what is happening with the rest of the system. Therefore, if it were to be used as a Zone Type in Output Device Programming, there would be no way to stop the event, as it does not require external intervention. However, should it be desired that a relay respond to this event, all zones which are of type 12 must be placed into their own zone list. In order to link a fault in this zone to a device, the Starting event would be fault, and the zone list would be the one containing the zone(s) which are of type 12. The stop action would be the restore of the zone list containing the zone(s) which are of type 12.

Zone Lists

(*81 Menu Mode)

In This Section

- ◆ About Zone List Menu Mode
- ◆ Zone List Displays
- ◆ Cross Zoning - Zone List 04
- ◆ NIGHT-STAY - Zone List 05
- ◆ Pager Reporting - Zone List 06

About Zone List Menu Mode

Zone List Menu mode is used to program zone lists for output devices (programmed in *80 Menu mode). Refer to the Programming Form worksheet for *81 Mode. To enter Zone List Menu mode, press *81 while in program mode.



Zone 92, DURESS, must **not** be programmed into any Zone List.

Zone List Displays

Zone List No. (00 = Quit) 01

Enter the Zone List Number **01, 02, 03, 04, 05** or **06** you want to program (or **00** to end these entries). Press * to advance.

In the following displays, zone list 01 has been selected for programming.

01 Enter Zn Num. (00 = Quit) 00

Enter each zone number to add to the zone list by first entering the zone number, then * (for example, 01*, 02*, 03*). After all zones desired are entered, press **00** to advance.

IMPORTANT: Do not include fire zones in zone lists that are used to STOP relay actions.

01 Del Zn List? 0 = No 1 = Yes 0
--

To delete the zone list, enter **1** (Yes). All zones in the zone list will be deleted automatically and programming will return to the first screen.

To save the zone list, enter **0** (No) to advance.

01 Delete Zone? 0 = No 1 = Yes 0
--

To save the entire zone list, enter **0** (No) and programming will return to the first screen.

To delete a zone or zones in a zone list, enter **1** (Yes) to advance.

01 Zn to Delete? (00 = Quit) 00

Enter each zone to be deleted from the list, followed by *. After all zones to be deleted are entered, enter **00** to return to the first screen so that another list can be programmed, if desired.



Any list may include any or all of the system's zone numbers **except** zone 92. A zone list can be assigned to more than one output relay.

Cross Zoning - Zone List 04

Cross alarm zone verification is an option that must be set up using zone list 04, the cross zone list, and entering the appropriate cross number corresponding to the cross zone delay time in field *85, the cross zone timer.

A cross zone is any combination of up to 10 zones of the following zone types:

- 01 - Entry/exit #1
- 02 - Entry/exit #2
- 03 - Perimeter
- 04 - Interior Follower
- 10 - Interior with Delay

The chosen zone numbers of the above types are to be entered into zone list 04 via field *81. If any of the zones fault in the armed state, the system will wait to see if another zone in the zone list faults within the cross zone list time entered in field *85. If another zone faults, alarms will be sent out for both zones, the bell will sound, and the alarms will be displayed on the keypad. However, if another fault does not occur within the programmed cross zone time, a Trouble report will go out to the Central Station and no message will be displayed on the keypad until the system is disarmed. Then a **CHECK** message will be displayed on the keypad. This message can be cleared by another **[4-digit code] + OFF** sequence. The default for the cross zone timer is 30 seconds. Zone list 04 is empty by default.

NIGHT-STAY - Zone List 05

This mode will only arm the Interior Follower and/or Interior with Delay zones programmed into this zone list. All other zones will be bypassed. The key sequence for arming in this mode is: **[4-digit code] + 3 + 3**. The installer will determine which zones are to be included in this list. The interior zones (interior followers or interiors with delay) will have the following characteristics:

ARMING MODE	INTERIOR ZONES	INTERIOR ZONES IN ZONE LIST 05
STAY	Bypassed	Does not apply
NIGHT-STAY	Bypassed	Armed

NOTE: When armed in this mode, the keypad will display **NIGHT-STAY**.

Pager Reporting - Zone List 06

All zones that are entered in this list will report to the pager if enabled.

Alpha Descriptor Programming

In This Section

- ◆ *About Alpha Descriptor Programming*
- ◆ *Programming Zone Descriptors*
- ◆ *Zone Descriptors*
- ◆ *Adding Custom Words*

About Alpha Descriptor Programming

This section provides instructions for programming alpha zone descriptors. This is recommended for systems using alpha keypads, and is necessary if a 4285 or 4286 VIP Module is used.

If you are using a 4285/4286 VIP Module, select from those words in the Alpha Vocabulary List shown in **boldface type**. **The phone module will not provide annunciation of the other words.**



If a 4285/4286 VIP Module is added to an existing 250P1 system, the alpha descriptors presently in the system should be reprogrammed. Select from those words shown in **boldface type** in the Alpha Vocabulary List; the phone module will not provide annunciation of any other words.

The Alpha Vocabulary List and Character (ASCII) Chart can be found on a page 19-4.

Zone Descriptors

For the alpha keypad used with the 250P1, you can program into the system a user-friendly English language description/location of all protection zones, keypad panics, and RF receiver supervision faults. Each description can be composed of a combination of words (up to 3) selected from a vocabulary of 196 words stored in memory (see a following page). In addition, up to 10 installer-defined words can be added to those already in memory. Thus, when an alarm or trouble occurs in a zone, an appropriate description for that zone's location will be displayed at the keypad.

NOTE: Alpha descriptor entry can be done locally at the alpha keypad or remotely using downloading software. The alpha keypad entry procedure is described below.

Programming Zone Descriptors (Program Menu Mode *82)

You can enter the descriptor when the zone is being defined in field *56, but we recommend you do it using *82 menu mode.

To program zone descriptors, enter the 3-digit reference number for the desired word(s). The 3-digit number for each word is provided in the Alpha Vocabulary List (on a following page).

1. With the system powered up, enter the Programming mode by keying:
Installer code (4 1 1 2) + 8 + 0 + 0. The following display will appear:

Installer Code
20

Program Alpha?
0=No, 1=Yes 00

2. Press ***82**.

The **Program Alpha?** prompt will appear.

Custom Words ?
0=No, 1=Yes 00

3. Press **1** (Yes).
The **Custom Words ?** prompt will appear.
 4. Press **0** (No).* The system will then automatically display the descriptor for zone 1.
- * The procedure for adding custom words to the built-in vocabulary is given in "Adding Custom Words" on the next page.

Summary Mode Display

Default Descriptor ↓

* ZN 01ZONE 01

If a descriptor was not entered previously for zone 1, the default descriptor for zone 1 will be displayed. Note that this is a "summary mode," and that no entries can be made. Entries can be made only when the display contains a flashing cursor, which signifies the "entry mode."

Flashing Cursor (system is ready for entry of word).



* ZN 01

5. To delete or change the default descriptor for zone 1, **press * plus the same zone number (01)**. This will clear that descriptor and allow changes to be made at the flashing cursor.
- NOTE:** If you do not wish to change the existing descriptor for zone 1, enter * plus the next zone number for which you wish to enter (or check) a descriptor. A summary display for that zone will appear. You must then press * plus the same zone number again to gain access to the entry mode (flashing cursor) for that zone.

Flashing Cursor ↓

* ZN 01 B]ACK

6. Press # plus the **3-digit number** for the first word from the Alpha Vocabulary List.

EXAMPLE: The descriptor that we wish to enter for zone 1 is BACK DOOR. From the list, BACK = 013. Therefore, we enter # **0 1 3**.

NOTE: If you accidentally enter the wrong word, simply press # plus the correct 3-digit number for the word you want.

* ZN 01 BACK

7. Press **6** to accept the selected word and continue.
- NOTE:** If this is the only word you are using for the descriptor, press **8** instead of **6** to save that word in memory, and then go to step 11.

↑
Flashing Cursor if "6" is pressed (system is ready for next word)

* ZN 01 BACK
 D]OOR

8. Enter the **3-digit number** for the next word. In our example, the word is DOOR, whose number is 057. Enter # **0 5 7**. The display at left will appear:

↑ Flashing Cursor

* ZN 01 BACK
DOOR

9. Press **6** to accept the selected word.
10. The two words in our example have now been entered. Note, however, that up to three words may be entered (provided the number of characters will fit on the screen). **Press 8 to save all words in memory.**

↑
Flashing Cursor if "6" is pressed (system is ready for next word)
Summary Display

* ZN 01 BACK DOOR

The flashing cursor will disappear, indicating that the word(s) are stored in memory for that zone, as shown in the summary display at the left.

11. To enter a descriptor for the next zone, press * plus the desired zone number (e.g., *02). The summary display following step 4 previously will appear. Now repeat Steps 6 through 10 for the descriptor for the next zone.
12. To exit the alpha descriptor mode, press *00 at the summary display.

Program Alpha? 0=No, 1=Yes 00

This prompt will be displayed.

Alpha Pgm 82

13. Press 0. This will be displayed.

14. Press *99 to exit the Programming mode.

Adding Custom Words

You can add up to 10 installer-defined words to the built-in vocabulary. Each of the 10 words can actually consist of a word string of one or more words, but no more than *ten* characters can be used for each word or word string.

When adding Custom Words, the keypad keys perform the following functions:
--

- | |
|---|
| <ul style="list-style-type: none"> [4] Moves cursor one space to the left. [6] Moves cursor one space to the right. [8] Saves the new word in the system's memory. |
|---|

1. Perform steps 1, 2, and 3 of *Programming Zone Descriptors* on a previous page. Select Custom Word mode (enter 1) when the prompt **CUSTOM WORD ?** is displayed.
2. Enter the number (**01–10**) of the custom word or word string to be created (for example, if you are creating the first custom word or word-string, enter **01**; for the second, enter **02**, etc.). A cursor will now appear at the beginning of the second line.
3. Refer to the Character Chart of letters, numbers, and symbols on a following page. Press #, followed by the 2-digit entry for the first letter you would like to display (for example, **65** for “A”). The cursor will then move to the right, in position for the next character.
4. Repeat Step 3 to create the desired word(s). Note that the “4” key can be used to move the cursor to the left, if necessary. Remember no word or word-string can exceed 10 characters.
5. Press **8** to save the custom word(s) and return to the “CUSTOM WORD ?” display. Repeat Steps 2–5 for other custom words to be entered. To change a custom word, just overwrite it. If no more are to be entered now, press **00** to return to the Program Alpha prompt. The custom word(s) will be automatically added to the built-in vocabulary.



If a custom word exists, and you want to replace that word with a shorter one, do the following: after the last character of the new word is entered, press 6 + 00 + 8. This removes all the additional characters of the old custom word.

When zone descriptors are being entered as described in Step 6 of *Programming Zone Descriptors*, the custom word numbers are 245 to 254 for words 1 to 10, respectively.

**ALPHA VOCABULARY LIST
(For Entering Zone Descriptors)**

NOTE: The list below is a revised vocabulary list that differs from lists for earlier versions of the VISTA-20. Use only this list when programming 250P1 zone descriptors.

000 (Word Space) A • 001 AIR • 002 ALARM 004 ALLEY 005 AMBUSH • 006 AREA • 007 APARTMENT • 009 ATTIC 010 AUDIO B • 012 BABY • 013 BACK • 014 BAR • 016 BASEMENT • 017 BATHROOM • 018 BED • 019 BEDROOM 020 BELL • 021 BLOWER • 022 BOILER 023 BOTTOM 025 BREAK • 026 BUILDING C 028 CABINET • 029 CALL 030 CAMERA 031 CAR 033 CASH 034 CCTV 035 CEILING 036 CELLAR • 037 CENTRAL 038 CIRCUIT • 040 CLOSED • 046 COMPUTER 047 CONTACT D • 048 DAUGHTERS 049 DELAYED • 050 DEN 051 DESK • 052 DETECTOR • 053 DINING 054 DISCRIMINATOR 055 DISPLAY • 057 DOOR • 059 DOWN • 060 DOWNSTAIRS 061 DRAWER • 062 DRIVEWAY	• 064 DUCT E • 065 EAST 066 ELECTRIC 067 EMERGENCY 068 ENTRY • 069 EQUIPMENT • 071 EXIT 072 EXTERIOR F • 073 FACTORY 075 FAMILY • 076 FATHERS • 077 FENCE • 079 FIRE • 080 FLOOR 081 FLOW 082 FOIL • 083 FOYER 084 FREEZER • 085 FRONT G • 089 GARAGE • 090 GAS 091 GATE • 092 GLASS 093 GUEST 094 GUN H • 095 HALL • 096 HEAT 098 HOLDUP 099 HOUSE I • 100 INFRARED • 101 INSIDE 102 INTERIOR 103 INTRUSION J 104 JEWELRY K • 105 KITCHEN L • 106 LAUNDRY • 107 LEFT 108 LEVEL • 109 LIBRARY • 110 LIGHT 111 LINE • 113 LIVING	• 114 LOADING 115 LOCK 116 LOOP 117 LOW • 118 LOWER M • 119 MACHINE 121 MAIDS 122 MAIN • 123 MASTER • 125 MEDICAL 126 MEDICINE 128 MONEY 129 MONITOR • 130 MOTHERS • 131 MOTION 132 MOTOR N • 134 NORTH 135 NURSERY O • 136 OFFICE • 138 OPEN 139 OPENING • 140 OUTSIDE 142 OVERHEAD P 143 PAINTING • 144 PANIC 145 PASSIVE • 146 PATIO 147 PERIMETER • 148 PHONE 150 POINT 151 POLICE 152 POOL • 153 POWER R 155 RADIO • 156 REAR 157 RECREATION 159 REFRIGERATION 160 RF • 161 RIGHT • 162 ROOM 163 ROOF S 164 SAFE 165 SCREEN 166 SENSOR • 167 SERVICE	• 168 SHED 169 SHOCK • 170 SHOP 171 SHORT • 173 SIDE 174 SKYLIGHT 175 SLIDING • 176 SMOKE • 178 SONS • 179 SOUTH 180 SPRINKLER • 182 STATION 184 STORE • 185 STORAGE 186 STORY 190 SUPERVISED 191 SUPERVISION 192 SWIMMING 193 SWITCH T 194 TAMPER 196 TELCO 197 TELEPHONE • 199 TEMPERATURE 200 THERMOSTAT • 201 TOOL 202 TRANSMITTER U • 205 UP • 206 UPPER • 207 UPSTAIRS • 208 UTILITY V 209 VALVE 210 VAULT 212 VOLTAGE W 213 WALL 214 WAREHOUSE • 216 WEST • 217 WINDOW • 219 WING 220 WIRELESS X 222 XMITTER Y 223 YARD Z 224 ZONE (No.) • 225 ZONE	• 226 0 • 227 1 • 228 1ST • 229 2 • 230 2ND • 231 3 • 232 3RD • 233 4 • 234 4TH • 235 5 • 236 5TH • 237 6 • 238 6TH • 239 7 • 240 7TH • 241 8 • 242 8TH • 243 9 • 244 9TH 245 Custom Word #1 _____ 246 Custom Word #2 _____ 247 Custom Word #3 _____ 248 Custom Word #4 _____ 249 Custom Word #5 _____ 250 Custom Word #6 _____ 251 Custom Word #7 _____ 252 Custom Word #8 _____ 253 Custom Word #9 _____ 254 Custom Word #10 _____
--	--	--	---	---

NOTE: Bulleted (•) words in **boldface type** are those that are also available for use by the 4285/4286 VIP Module. If you are using a phone module, and words other than these are selected for alpha descriptors, the phone module will not provide annunciation of those words.

**CHARACTER (ASCII) CHART
(For Adding Custom Words)**

32 (space)	39 ' (apostrophe)	46 . (period)	53 5	60 <	67 C	74 J	81 Q	88 X
33 ! (exclamation)	40 ((left paren)	47 / (slash)	54 6	61 = (equals)	68 D	75 K	82 R	89 Y
34 " (quotation)	41) (right paren)	48 0 (zero)	55 7	62 >	69 E	76 L	83 S	90 Z
35 # (hash)	42 * (asterisk)	49 1	56 8	63 ? (question)	70 F	77 M	84 T	
36 \$ (dollar)	43 + (plus)	50 2	57 9	64 @ (at)	71 G	78 N	85 U	
37 % (percent)	44 , (comma)	51 3	58 : (colon)	65 A	72 H	79 O	86 V	
38 & (ampersand)	45 - (dash)	52 4	59 ; (semicolon)	66 B	73 I	80 P	87 W	

Function Key Programming (*83, *86)

◆ About Function Key Programming

◆ Special Function Programming (*86)

◆ Programming Procedures (*83)

◆ Macro Key Programming

About Function Key Programming

This 250P1 system provides the ability to program each of the four function keys, on the 6150PL2 and/or 6160PL2 hard-wired keypads, to perform one of 11 system operations.

Programming Procedures (*83)

Note: Before proceeding, you must program field *22 (RF System) and field *25 (Wired Zone Expansion) as required.

Enter Programming mode [**Installer Code**] + **8 + 0 + 0** on the keypad. Enter Function Key Programming mode by pressing ***83**. The following prompts will be displayed in response to the entries made:

Enter Key No. (00 = Quit) 01

Press the digits that represent the Function Key you want to program. At the flashing cursor press 01 for the A key; press 02 for the B key; press 03 for the C key; or press 04 for the D key. Press [*] to continue.

Key "A" Function Panic Zone 95 00

Enter the function this key will perform, 00 to 11, from the options listed below. (00 selected for example display shown at left).

00 If selected, each Function key will be mapped as follows:

A = Zone 95

B = Zone 99

C = Zone 96

D = Single-button paging (sends a 999-9999 message to pager).

01 Arm *AWAY* - Reports as User 0 if closing reports are enabled.

02 Arm *STAY* - Reports as User 0 if closing reports are enabled.

03 Arm *NIGHT-STAY* - Reports as User 0 if closing reports are enabled.

04 Lights ON/OFF toggle - If selected, Function Keys A through D will be tied to relays 1 through 4, respectively. Pressing the function key will activate the associated relay.

05 Cancel Key - Sends a cancel report to the Central Station after an alarm has occurred. This key **MUST** be used as a fifth key within 4 seconds of a 4-digit disarm, or immediately after a 4-digit code. Cancel Verify (*52) must be enabled, and Cancel Report code (*68) must be entered for the key to function correctly.

06 Single-Button Communicator Test - Sends the same code as a manual TEST (e.g., contact ID code 607).

07 Single-Button Page - Sends a 999-9999 message to a pager when pressed.

- 08 One shot 10-second Time/Date display.
- 09 Macro Key - Performs the macro function (programmed separately - see **Macro Key Programming** later in this section).
- 10 Special Function #1 - Sends a special message when initiated, (see **Special Function Programming** later in this section).
- 11 Special Function #2 - Sends a special message when initiated, (see **Special Function Programming** later in this section).
- 12 Not Used

A-B-C-D KEY DEFAULTS

KEY	DEFAULT	FUNCTION
A (01)	05	CANCEL
B (02)	06	TEST
C (03)	12	Not Used
D (04)	10	SPECIAL FUNCTION #1

Special Function Programming (*86)

This field lets you define the special functions (#1 or #2) selected in field *83. These functions will only be activated if:

- you program one or more of the keypad function keys for one of the special functions (10 or 11) available above in field *83, and
- you press the key to initiate the function.

To define these functions, enter *86 from programming mode. The following prompt will appear:

Spec Funct Setup (00 = Quit) 01

Enter the special function to program, either 01 (corresponding to #1 from *83) or 02 (corresponding to #2 from *83).

Enter CID Code 751

With Contact ID reporting to the Central station programmed, or if sending the message to a pager, enter the second two digits of the Contact ID code that will be sent when the special function is initiated, 50 to 89. Defaults are: 01 = 751 and 02 = 752.

01 Report Code 1st 01 2nd 00 10

With Contact ID report format, enter "01" as the first digit of the report code and "00" as the second digit to enable the dialer. If no Contact ID message is being sent, enter "00" for both digits. Default is 10 (no message will be sent), as shown at left.

Report/Log As Alarm 1

Select whether you want to associate this function with an alarm or with a trouble for the purpose of reporting to primary/secondary destinations and event logging. Defaults are 1 for both (Alarm).

Add to Zn List 6 0 = No 1 = Yes 0

Select whether you want this report to be added to Zone List 6 for paging purposes. Defaults are 0 (No) for both.

Sounder Option Silent 0

Enter the system sounder(s) response to the initiation of the function from the following options:
 0 = silent-This is the default setting for both special functions.
 1 = sound keypad only
 2 = ring bell(s) only
 3 = ring bell and sound keypad

Program Alpha? 0 = No 1 = Yes 0

If you would like the keypad to display a description of the function, enter alpha programming by entering 1 (Yes). Refer to **Section 19: Alpha Descriptor Programming**. If not, enter 0 (No) which is the default setting for both special functions.

Macro Key (Speedkey) Programming

The A, B, C, or D key can be used to activate a series of commands, represented by strings of up to 16 keystrokes. These keystrokes, as a group, are called macros and are stored in the system's memory. Typical Speedkey functions include:

- Arming sequences that first involve bypassing certain zones before arming
- Seldom used but repeatable sequences
- Relay activation sequences.

To Program a Macro

To program a macro, enter the 4-digit security code + [#] + [X], where X can be the A, B, C, or D key.

The following prompt appears:

SPEED LEARN MODE

For example, you may want to perform the following:

Desired Function	Keystrokes Required
Bypass zones 02 and 19	Press BYPASS [6] key, then 2-digit zone numbers 02 and 19.
End the command	Press the MACRO key.
Turn on relay 1. (e.g., Relay 1 operates the porch light)	Press [#] key, then the [7] key for relay on, and the [1] key for selecting relay 1.
End the command	Press the MACRO key.
Arm system in AWAY mode	Press AWAY [2] key.
End the command	Press the MACRO key.

You can enter up to 16 keystrokes to program a macro. The keyboard display echoes the keys that are pressed. **Any pressed MACRO key will appear as an "F" on the display.**

At this point, the display will appear as follows:

SPEED LEARN MODE
60219F#71F2F

To exit the MACRO mode, press the MACRO key again and the display will disappear. Note that the MACRO key is pressed only once after each command. Press the MACRO key twice to complete the MACRO and exit this mode. The other function keys are disabled while in MACRO programming mode.

To Execute a Macro

To start a speedkey sequence, press the MACRO key.

The following display will appear:

ENTER USER CODE

Enter the 4-digit user code. The programmed speedkey sequence will begin automatically.

NOTE: There is only one macro program available per system. If more than one macro is programmed, only the latest macro will be retained by the system.



When defining speedkey sequences, do **NOT** use the [#] key to represent Quick Arming. The 250P1 system uses the entered code in response to the prompt to initiate commands in a speedkey sequence, so the Quick Arm key is unnecessary. The system interprets the use of the [#] key in a speedkey sequence as its designated function only.

Remote Programming and Control (Downloading)

In This Section

- ◆ *About Remote Programming*
- ◆ *Equipment Required*
- ◆ *Initial Download*
- ◆ *Remote Programming Commands*
- ◆ *Remote Programming Advisory Notes*

About Remote Programming

The 250P1 can be remotely programmed from an IBM-compatible personal computer (PC), a compatible modem, and ADEMCO's COMPASS software (as specified below).

UL

Downloading may be performed only if a technician is at the site.

The following multiple levels of security protect remote programming of the control against compromise by someone attempting to defeat the system:

- 1. Security Code Handshake:** An 8-digit download ID code must be matched between the control and the downloader.
- 2. Site-Initiated Remote Programming:** The installer or subscriber initiates the callback from the subscriber premises (by entering **[Installer code] + # + 1**) while disarmed. All parameters can then be downloaded via the phone lines using a personal computer.
- 3. Station-Initiated Remote Programming:** The operator calls the site from your office to initiate the download call. The control hangs up and then calls back the PC via the preprogrammed telephone number. The unit can then be uploaded, downloaded, or controlled from your office.
- 4. Telco Hand-off:** Allows the installer or subscriber to perform a download session on the call initiated from the site.
- 5. Data Encryption:** Data passed between the PC and the control is encrypted for security so that it is very difficult for a foreign device tapped into the phone line to take over communication and substitute system-compromising information.

Equipment Required

The following equipment is required for remote programming and downloading:

At the premises:

- 250P1 and keypad

At the installer's office/home:

- An IBM PC-compatible computer
- One of the following modems:

BizComp Intellimodem 1200 w/volume
BizComp Intellimodem 2400
Hayes Optima 336 External
Hayes Smartmodem Optima 2400
Hayes Optima 2400 Fax96
Hayes Smartmodem 1200 External Modem
Hayes Smartmodem 1200B Internal Modem (Rev. 1.2 or higher)
Hayes external Optima 24 Plus FAX96 Modem
Practical Peripherals PM14400FXSA

- COMPASS® Downloader Software (at revision level supporting the 250P1)
- Appropriate interconnecting cables

Initial Download

For initial downloading, enter **[Installer code] + # + 5**. This sets field *95 to 4 rings, and system to “no call-back” option. The download computer can then call the subscriber, make the connection, and download all programming items.

After the control and the PC have established valid communication, each keypad on the system will become inactive and will display “**CC**” or “**MODEM COMM.**” The control, however, will still be scanning its zones and looking for alarms. If an alarm does occur, after communication is broken off, alarms are sounded and the proper dialer reports are sent to the Central Station. The keypads will become active after the download communication is terminated. The detailed operation of the download functions is covered in the installation instructions for the COMPASS Downloader.

Remote Programming Commands

The downloading system can perform many functions when in communication with the control unit. Besides uploading and downloading, the status of the system can be observed and various commands can be initiated, as follows:

- Arm the system in the AWAY mode; disarm the system.
- Bypass a zone.
- Set the time.
- Force the system to accept a new program download.
- Shut down communication (dialer) functions (in response to nonpayment of monitoring fees in an owned system).
- Shut down all security system functions (in response to nonpayment for a leased system).
- Inhibit local keypad programming (prevents account takeover).
- Command the system to upload a copy of its resident program to the office.
- Read: arming status, AC power status, lists of faulted zones, bypassed zones, zones currently in alarm, zones currently in trouble, RF sensors with low-battery conditions, and time and event log.

Remote Programming Advisory Notes

- Alarm and trouble reporting may be delayed during the time that the system and the downloader are linked to each other following a valid exchange of codes, but the proper message will get through to the Central Station after the link is broken.
- Keypad entries are ignored during the time interval stated above.
- A copy of the program downloaded may be produced from the IBM PC-compatible computer, using the product's internal report generator, when an optional printer is connected (consult your PC manual for proper printer and connections).

System Communication

In This Section

- ◆ *Panel Communication with Central Station*
- ◆ *ADEMCO Contact ID Reporting*
- ◆ *Report Code Format*

Panel Communication with Central Station

This system accommodates two Contact ID formats for reporting alarms and other system conditions to the Central Station. The process of a successful transmission consists of both the method of communication between the control panel and the Central Station receiver; and the actual way the information is sent and displayed at the Central Station.

When the panel calls the Central Station receiver, it waits to hear a “handshake” frequency from the receiver to confirm that the receiver is on-line and ready to receive its message. Once the panel hears the handshake it is programmed to listen for, it sends its message. The panel then waits for a “kissoff” frequency from the receiver acknowledging that the message was received and understood.

If the handshake frequency is not given or is not understood by the panel, the panel will not send its message. Once the handshake frequency is received and understood by the panel, the panel will send its message. If there is an error in the transmission (the receiver does not receive a “valid” message), the kissoff frequency will not be given by the Central Station receiver.

The panel will make a total of eight attempts to the primary telephone number and eight attempts to the secondary telephone number (if programmed) to get a valid message through. If the panel is not successful after its numerous attempts, the keypad will display **COMM. FAILURE** (on alpha keypads) or **FC** (on fixed-word keypads).

Report Code Formats

The following chart indicates the characteristics of the ADEMCO Contact ID reporting that the 250P1 panel supports:

FORMAT TYPE	HANDSHAKE	TRANSMITS DATA	KISSOFF	TRANSMIT
Contact ID	1400–2300 Hz	DTMF (10 cps)	1400 Hz	Under 3 secs

The ADEMCO Contact ID reporting format comprises a 10-digit or a 4-digit subscriber account number, 1-digit event qualifier (“new” or “restore”), 3-digit event code, and 3-digit zone number, user number, or system status number, as follows:

ADEMCO Contact ID Reporting takes the following format:

CCCCCCCCC Q EEE ZZZ

where:

CCCCCCCCC = Customer ID (subscriber account number)

Q = Event qualifier, where: E = new event, R = restore

EEE = Event code (3 hexadecimal digits)*

ZZZ = Zone/contact ID number reporting the alarm, or user number for open/close reports. System status messages (AC Loss, Walk Test, etc.) contain zeroes in the ZZZ location.

* **NOTE:** For a complete list of event codes, refer to the Central Station office receiver manual.

TABLE OF CONTACT ID EVENT CODES

Code	Definition
110	Fire Alarm
121	Duress
122	Alarm, 24-hour Silent
123	Alarm, 24-hour Audible
131	Alarm, Perimeter
132	Alarm, Interior
134	Alarm, Entry/exit
135	Alarm, Day/Night
143	Alarm, Expansion Module
146	Silent Burglary
150	Alarm, 24-Hour Auxiliary
301	AC Power
302	Low System Battery/Battery Test Fail
305	System Reset
321	Bell/Siren # 1 Trouble
333	Trouble or Tamper Expansion Module
344	RF Receiver Jam Detection
351	Telco Line Fault
353	Long Range Radio Trouble
373	Fire Loop Trouble
374	Exit Error Alarm

Code	Definition
380	Global Trouble, Trouble Day/Night
381	RF Supervision Trouble
383	RF Sensor Tamper
384	RF Sensor Low Battery
401	Disarmed, Armed AWAY (Max), Armed AWAY
406	Cancel by User
407	Remote Arm/Disarm (Downloading)
408	Quick Arm AWAY/Max
441	Disarmed/Armed STAY/INSTANT, Quick Arm STAY/INSTANT, Arm NIGHT-STAY
570	Bypass
602	Periodic Test
606	AAV to Follow
607	System Test
623	Event Log 80% Full
629	1-1/3 Day No Event
750 to 789	Special Function key (#1 or #2) event codes.

System Operation

In This Section

- ◆ Security Codes
- ◆ Keypad Functions
- ◆ Relay/Powerline Carrier Devices
- ◆ 4285/4286 VIP Module
- ◆ Exit Error Alarm Displays
- ◆ Trouble Conditions
- ◆ Setting the Real-Time Clock

Security Codes

Installer Code

The installer programs the 4-digit Installer code initially as part of the programming procedure. The factory default Installer code is **4-1-1-2**, but may be changed in field *20.

The Installer code is the only code that can enter Programming mode. In Normal Operation mode, it is also used to enter the Master code, which allows access to the normal functions of the system.

Master Code

In Normal Operation mode, the Installer code is used to enter the 4-digit Master security code using *the hardwired connected keypad*. Therefore:

To enter the system's Master code, enter:

[Installer code] + 8 + 02 + [desired 4-digit Master code]

To change the Master code, enter:

[Master code] + 8 + 02 + [new Master code] + [new Master code again]

Secondary User Codes

In Normal Operation mode, the Master security code can be used to assign up to 13 Secondary 4-digit security codes, including a Temporary code and a Duress code. The Master code is also used to remove any Secondary User code(s) from the system (individually).

To assign (or change) a Secondary security code, enter the following on the keypad:

[Master code] + CODE key + User # [03-15] + [desired Secondary Code]

The system will emit a single beep when each secondary code has been successfully entered.

To delete a Secondary security code, enter the following on the keypad:

[Master code] + [CODE] key + [User No.] [(03-15)]

Temporary User Code: This user code can only be assigned to User 14 (**[Master code] + 8 + 14 + [desired 4-digit Temporary code]**) on a strictly temporary basis because *whenever* a 4-digit Master code is keyed into the keypad, the existing Temporary code is removed.

NOTES:

- All Master and Secondary User security codes permit access to the system for arming, disarming, etc.
- The Installer code can disarm the system only if it was used to arm it.
- Temporary code (User 14) behaves as Secondary User codes 3 through 13, except that a keypad entry of a Master code will permanently disallow use of this code.
- Duress code is User code No. 15;. When this is used to perform any system operation, a special code is sent to the monitoring station. Instruct users to be careful not to use this code for normal usage.

- If a Secondary User code is inadvertently repeated for different users, the lower user number will take priority.
- Opening and Closing reports are sent for the Installer code as No. 01, with the appropriate subscriber number. Each Master code and set of Secondary User codes are sent as Nos. 02 and 03–15, respectively, in Contact ID format (with the appropriate subscriber number).

Keypad Functions

Arming and Disarming

The keypad allows the user to arm and disarm the system, and to perform other system functions, such as bypass zones and display zone descriptors. Zone and system conditions (alarm, trouble, bypass) are displayed in the display window.

All keypads with backlighting capability will automatically illuminate when system is placed in entry mode.

If you enabled Quick Arm for the system (field *21), you can press # instead of entering the system's security code, for any of the arming procedures (STAY, NIGHT-STAY, etc.). Arming levels **cannot** be increased or decreased by the use of this Quick Arm feature. The 250P1 has the ability to increase the arming level with a single button if the function keys are programmed with arming levels in *83. The arming levels in increasing order are **STAY, NIGHT-STAY, INSTANT, AWAY** and **MAXIMUM**. Arming level increases/decreases can be accomplished using code + #(s) to indicate arming state. These arming level changes transmit an Opening report followed by the appropriate report of the armed state to the Central Station. The security code is always required, however, when disarming the system.

When an alarm occurs, keypad sounding and external sounding will occur, and the zone(s) in alarm will be displayed on the keypad. Pressing any key will silence the keypad sounder for 10 seconds. Disarming the system will silence both keypad and external sounders. If the system is armed, and an alarm has occurred, or you are in entry mode, you can disarm the system by entering only the 4 digit user code. When the system is disarmed, any zones that were in an alarm condition during the armed period will be displayed. To clear this display, simply repeat the disarm sequence (enter the security code and press the OFF key) again.

Arming Commands

The following is a brief list of system commands. For detailed information concerning system functions, refer to the User Guide.

- Disarmed, Not Ready** Before arming, the system must be in the Ready condition (all zones must be intact). If the **NOT READY** message appears, press * (READY key) to display faulted zones.
- Arming AWAY**.....Enter code + 2 (AWAY), or # + 2[†], or press Function key programmed as AWAY.
- Arming STAY**.....Enter code + 3 (STAY), or # + 3[†], or press Function key programmed as STAY.
- Arming NIGHT-STAY** Enter code + 3 (STAY) + 3 (STAY), or # + 3 + 3[†], or press Function key programmed as NIGHT-STAY.
- Arming INSTANT**Enter code + 7 (INSTANT), or # + 7[†].
- Arming MAXIMUM**.....Enter code + 4 (MAXIMUM) or # + 4[†].
- Disarming**.....Enter code + 1 (OFF), or code only if an alarm has occurred and you are in an entry mode.
- Bypassing Zones**Enter code + 6 (BYPASS) + zone number(s).
- Forced (Quick) Bypass**....(If enabled) To automatically bypass all faulted zones, use the "Quick Bypass" method: Enter code + 6 (BYPASS), then wait for all open zones to be displayed. Arm when display indicates **BYPASS** and **READY TO ARM**.

[†] if Quick Arm is enabled in *21

- Chime Mode**Enter code + 9 (CHIME).
To turn chime off, enter code + 9 (CHIME) again.
- NIGHT-STAY**Enter code + 3 + 3, which only arms the Interior Follower and/or Interior with Delay zones programmed in zone list 05. All other zones will be automatically bypassed. The installer will determine which zones are to be included in this list.
The interior zones (Interior or Interiors with Delay), will have the following characteristics:

Arming Mode	Interior Zones	Interior Zones in Zone list 5
STAY	Bypassed	Does not apply.
NIGHT-STAY	Bypassed	Armed

SUMMARY OF ARMING MODES

Arming Mode	Features of Each Arming Mode			
	Exit Delay*	Entry Delay	Perimeter Armed	Interior Armed
STAY	Yes	Yes	Yes	No
NIGHT-STAY	Yes	Yes	Yes	Yes (Zone List 05)
INSTANT	Yes	No	Yes	No
AWAY	Yes	Yes	Yes	Yes
MAXIMUM	Yes	No	Yes	Yes

* The 250P1 contains an Exit Restart feature which allows the user to exit (fault), close the door (restore the fault), then re-enter (fault again) the premises within the exit delay time period. Upon re-entering, a new exit delay time period is begun with the keypad annunciating three rapid beeps. This feature will only restart the exit delay one time for each arming session.

PANIC Keys

There are three PANIC key-pairs **OR** (on 6160PL2 keypads if Quick Arm is disabled in field *21) lettered keys that can be used to manually initiate alarms and send a report to the Central Station.

Each lettered key may be individually programmed for 24-hour Silent, Audible, Personal, or Fire Emergency responses. The Panic function is activated when both keys of the appropriate key-pair are pressed at the same time, or the appropriate lettered key is pressed for at least 2 seconds.

The Panic functions are identified by the system as follows:

Keys	Display
1 + * , or A	95
* + # , or B	99
3 + # , or C	96
D	Pager Msg sent

Notes:

- When function keys A, B, C, and D are available, the keys may be programmed to provide the conditions as shown at left. (In field *83, press 00 at each **Key "X" Function** display.)
- Function keys may be programmed for other individual responses in *83. For example, in *83, the D (04) key may be programmed separately to send a 999-999 message to a pager by pressing 07.

Important: For the Silent Panic functions to be of practical value, the system must be connected to a Central Station.

Relay/Powerline Carrier Device Activation

If relay outputs (via a 4204 or 4229) or Powerline Carrier devices are used, two keypad entries available to the user are included. They can manually activate or deactivate the device(s) for starting or stopping some action, such as turning lights on or off, etc.

These keypad entries are:

[Security Code] + # + 7 + [Device No.] activates (starts) that device.

[Security Code] + # + 8 + [Device No.] deactivates (stops) that device.

4285/4286 VIP Module (if used)

Refer to the separate instructions supplied with the Phone Module for information concerning its operating procedures.



The phone module **cannot** be used to add user codes in this system. User codes must be added by using a wired keypad.

Exit Error Alarm Displays (if programmed)

- A display of **CANCELED ALARM** or **CA** and a zone indication will appear if an exit or interior zone contained a fault during closing at the time the Exit Delay ended (e.g., exit door left open), but the system was disarmed during the Entry Delay time. The alarm sounder and keypad sound continuously, but stop when the system is disarmed. No message will be transmitted to the Central Station.
- A display of **EXIT ALARM** or **EA** and a zone indication will appear when the Exit Delay ends if an exit or interior zone contained a fault during closing. The alarm sounder and keypad sound continuously until the system is disarmed (or timeout occurs). An "**Exit Alarm**" message is sent to the Central Station.
- The **EXIT ALARM** display and zone indication will also result if an alarm from an exit or interior zone occurs within 2 minutes after the end of an Exit Delay.

In any of the above cases, use a second Off sequence (code plus OFF key) to clear the display.

Trouble Conditions Displays

The word **CHECK** on the keypad's display, accompanied by a rapid beeping at the keypad, indicates that there is a trouble condition in the system. Pressing any key will silence the audible warning sound. Instruct users to call for service immediately upon seeing any of the following messages. (See **Section 25: Troubleshooting Guide** also).

CHECK and BATTERY Displays

- A display of **CHECK** and one or more zone numbers indicates that a problem exists with the displayed zone(s) and requires attention.
NOTE: The control will sense a high resistance in the loops on hardwired zones 2–6 and display **CHECK** and the affected zone number when the system is in the disarmed mode. A Trouble report may be sent to the Central Station depending on the Hardwire Short Detection field programmed setting and the zone type. See Hardwire Short Detection option in **Section 15: Data field Descriptions**. It will not be possible to arm the system as long as this condition exists (unless this zone is bypassed). If the system is in the armed mode when the high resistance condition occurs, this display will not appear, but will do so as soon as the system is disarmed. Check the sensor or the loop wiring for the displayed zone.

When the problem has been corrected, the display can be cleared by entering the Off sequence (code plus OFF key) **twice**.

- A display of **CHECK** and **09** indicates that communication between control and a zone expander or wireless receiver is interrupted. Check the wiring and/or DIP switch settings on the units.
- If there are wireless sensors in the system, the **CHECK** condition may also be caused by some change in the environment that prevents the receiver from receiving signals from a particular sensor.
- A display of **BAT** (on fixed-word keypads) or **SYSTEM LO BAT** (on alpha keypads) with **no** zone number indicates that the system's main standby battery is weak.
- A display of **BAT** (on fixed-word keypads) or **LO BAT** (on alpha keypads) **with** a zone number **and** periodic beeping at the keypad indicates that a low-battery condition exists in the wireless sensor displayed (zone **00** indicates a wireless keypad). If the battery is not replaced within 30 days, a **CHECK** display may occur.

NOTE: Some wireless sensors contain a nonreplaceable long-life battery that requires replacement of the entire unit at the end of battery life (for example, Nos. 5802, 5802CP, 5803).

Telephone Line Failure

A display of **94** (on fixed-word keypads) or **TELCO FAULT** (on alpha keypads) indicates that a monitored telephone line (if programmed in field *92) has been cut (or disconnected). Depending on how the system was programmed, the keypad may also produce a trouble sound, and the external sounder may be activated. Silence by entering Installer code plus OFF.

Power Failure Displays

- If there is **no** keypad display **at all** and the **POWER** indicator (if present) is not lit, operating power for the system has been lost and the system is inoperative.
- If the message **AC LOSS** (on alpha keypads) or **NO AC** (on fixed-word keypads) is displayed, and the **POWER** indicator (if present) is off, the system is operating on battery power only.
- If the battery standby capacity is used up during a prolonged AC power outage, the control's auxiliary power will shut down to minimize deep discharge of the battery.

Other Displays (fixed-word displays are in parentheses)

Busy-Standby (dI) If this remains displayed for more than 1 minute, the system is disabled.

Modem Comm (CC) The system is in communication with the Central Station for change of function or status verification.

Comm. Failure (FC) A communication failure has occurred.

Open-circuit (OC) The keypad is not receiving signals from the control and sees an open-circuit.

Long Rng Trbl (bF) Backup LRR communication failure.

Bell Failure (CHECK 70) Bell supervision failure.

Rcvr Jam (CHECK 90) RF Receiver jam detected.

Setting the Real-Time Clock

General Information

This system provides a real-time clock that must be set in order for the system's event log to keep track of events by time and date.



Use a 6160PL2 (2-line alpha keypad) to set the real-time clock, or set the clock via the downloader software. Only users with Installer or Master authority level can set the real-time clock.

Setting the Time and Date

1. Enter [**4-digit Installer or Master code**] + # + **63**.

The LCD display keypad will indicate the following:

TIME/DATE	FRI
12:00AM	01/01/99

The above display will disappear in one minute if no entries are made or if the # key is pressed. If this happens and you still want to make changes, repeat step 1.

2. Press the * key to change the Date/Time setting. The display will revert to the following:

TIME/DATE	FRI
12:00A1999/01/01	

3. The blinking cursor appears on the first digit of the hour to begin. Enter the time (hour, then minute). After each entry, the cursor moves to the right.
4. Press any odd-digit key for PM, or any even-digit key for AM.
5. Enter the 4-digit year and the 2-digit month in sequence. The day of the week is automatically calculated and displayed based on the date entered.
6. Look over the display to make sure it is correct. To change incorrect information, press the # key, which moves the cursor one space to the left, until the cursor sits on the improper entry. Then press the correct key(s).
7. Press the * key until the cursor is at the far right position.
8. To accept all of the clock information, press the * key again. The top display appears.
9. Exit clock mode by pressing # key.

Testing the System

In This Section

◆ Test Procedure

Test Procedure

After installation is completed, the security system should be carefully tested, as follows.

1. With the system in the disarmed state, check that all zones are intact. If a **NOT READY** message is displayed, press * to display the faulted zone(s). Restore faulted zone(s) if necessary, so that the **READY** message is displayed. Fault and restore every sensor individually to assure that it is being monitored by the system.
2. Enter the 4-digit Security code and press the TEST key. The outside sounder will sound for 1 second. The keypad should sound 3 beeps each time a contact is faulted. A "Test" report is transmitted (if programmed) to the Central Station immediately. If the backup battery is discharged or missing, the sounder may not turn on and a "Low Battery" report will be transmitted with a "Test" report. The keypad will beep once per minute as a reminder that the system is in the Test mode. To turn off the Test mode, enter 4-digit Security code and press the OFF key.

NOTE: Triggering a zone set to **Arm AWAY**, **Arm STAY**, **NIGHT-STAY**, or **Disarm** will take the system out of Test mode and cause that action.

Alarm messages will be sent to the Central Station during tests 3 and 4, below. Notify Central Station personnel in advance that tests will be in progress.

3. Arm the system and fault one or more zones. After 15 seconds (if Optional Dialer Delay is selected), silence alarm sounder(s) by entering the **Security code** and pressing OFF key. Check entry/exit delay zones.
4. Check the keypad-initiated alarms that are in the system by pressing the PANIC key (key pairs on some keypads). If the system has been programmed for audible emergency, the keypad will emit a **steady** alarm sound, and **ALARM** and zone number will be displayed. Silence the alarm by entering the **Security code** and pressing OFF key.

If the system has been programmed for Silent Emergency, there will be no audible alarms or displays, but a report will be sent to the Central Station.

5. If output Relay Units/Powerline Carrier devices have been installed, test their programmed action.
6. Notify Central Station personnel when all tests are finished, and verify results with them.
7. To test the wireless part of the system and the RF receiver, perform the following two additional tests:
 - a. **TRANSMITTER SNIFFER MODE**
Make sure the system is disarmed before trying to enter this mode.
Press [**Installer code**] + # + 3 on the keypad. This initiates a procedure to verify that all transmitters have been properly programmed.

NOTE: If the communicator is in the process of sending a report to the Central Station, the system will not go into the Sniffer mode. If so, wait a few minutes, and try again.

The keypads will display all zone numbers of wireless units programmed into the system. As the system receives a signal from each of the transmitters, the zone number of that transmitter will disappear from the display. The transmitter codes may be checked upon installation, or in an installed system.

All the wireless zone numbers should disappear after about 90 minutes.

NOTES:

- All BR-type units must physically be activated to clear the display.
- When **one** button of a transmitter (RF, UR, or BR) is activated, all zones assigned to other buttons on that transmitter are cleared. This also applies to 5816 and 5817 transmitters that have multiple loops (zones).
- Any transmitter that is not “enrolled” will not turn off its zone number.

Exit this mode by keying **[Installer code] + OFF**.

- b. **GO/NO GO TEST MODE:** By pressing **[Installer code] + # + 4** on the keypad, a mode similar to the user Test mode (code + TEST) is entered, but the wireless receiver gain is reduced. Checking in this mode assists in determining good mounting locations for the transmitters when the system is being installed, and verifies that the RF transmission has sufficient signal amplitude margin for the installed system.

Exit the mode by entering **[Installer code] + OFF**.

NOTE: System Test mode ([Installer code] + TEST) will be **automatically terminated** after 4 hours if the installer or user does not manually terminate it. This ensures that fire and panic zones will not remain disabled. However, **Sniffer mode** ([Installer code] + [#] + 3) **does not automatically expire**. You must manually exit ([Installer code] + OFF) sniffer mode to return to normal operation. Sniffer mode also terminates if a user arms the system.

TO THE INSTALLER

Regular maintenance and inspection (at least annually) by the installer and frequent testing by the user are vital to continuous satisfactory operation of any alarm system.

The installer should assume the responsibility of developing and offering a regular maintenance program to the user as well as acquainting the user with the proper operation and limitations of the alarm system and its component parts. Recommendations must be included for a specific program of frequent testing (at least weekly) to ensure the system's proper operation at all times.

Troubleshooting Guide

SYSTEM (including Wireless)

SYMPTOM	POSSIBLE CAUSE	REMEDY
1. Transmitter signal not received at 5881/5882.	1a. Transmitter or 5881/5882 not properly powered. 1b. If transmitter is 5827/5827BD, House Code not set in field *24, or transmitter not set to same House Code set in that field. 1c. Transmitter located too far from RF receiver. 1d. Metal shielding between transmitter and RF receiver. 1e. Transmitter malfunctioning. 1f. 5881/5882 malfunctioning. 1g. Transmitter no. (zone) not programmed. 1h. 5881/5882 address incorrect. 1i. Field *22 not set properly.	1a. Check or change transmitter's battery. Check 250P1's AC power. 1b. Check code switches inside transmitter. Must match with RF House Code programmed in 250P1. 1c. Move transmitter or RF receiver. 1d. Check for large metal obstructions, then relocate transmitter if necessary. 1e. Verify by activating 5881/5882 with another, similar transmitter. If O.K. now, return defective transmitter. 1f. Verify by making sure other transmitters cannot activate 5881/5882. If defective, replace and return original 5881/5882. 1g. Verify programming. 1h. Set DIP switch on 5881/5882 for address "0." 1i. Set field *22 for "1."
2. Transmitter zone number appears during Transmitter Sniffer mode, but does not clear.	2a. Transmitter zone type (ZT) is set to 00 (Not Used). 2b. Transmitter battery not installed. 2c. 5800 system transmitter not enrolled in system.	2a. Set ZT to a valid active zone type in field *56. 2b. Install proper battery. 2c. Enroll unit in field *56 or *83.
3. LOW BATTERY message on keypad.	3a. Bat or System Lo Bat (no zone nos.): System battery is low or missing. 3b. Bat or Lo Bat + 00 : Remote RF keypad battery is low. 3c. Bat or Lo Bat + nn : Transmitter for zone "nn" has a low battery.	3a. Verify that battery charging circuit is working. If ok, replace battery. 3b. Replace remote RF keypad battery 3c. Replace transmitter battery in zone "nn."
4. Periodic beep(s) from keypad	4a. System is in Test mode. 4b. A transmitter low battery has occurred and is displayed. 4c. A supervision Check has occurred.	4a. Enter [Code] + OFF to exit Test mode. 4b. Enter [Code] + OFF and replace the battery. 4c. Check the transmitter indicated. Restore communication to the receiver to cancel the condition.
5. With 5800 system, no response to a transmitter in normal operation, although zone number clears during Transmitter Sniffer mode.	5a. Put control in Test mode. If zone does not respond, try operating the tamper switch or another input to the transmitter. If another input causes the zone to be displayed, the wrong input was enrolled when programming. 5b. If no response at all from this transmitter, this physical transmitter has not been enrolled by the system. Transmitter Sniffer display is being cleared by another unit programmed for this zone.	5a. Delete input's serial number (not the zone), and enroll the proper input (see field *56). 5b. Determine which transmitter is programmed for this zone and reprogram as necessary.

SYSTEM (including Wireless - cont'd)

SYMPTOM	POSSIBLE CAUSE	REMEDY
6. Nuisance or phantom alarm.	6a. Sensors not properly installed, wired, or monitored. 6b. Universal transmitter (5817) programmed wrong.	6a. Check installation to see if in accordance with established procedure. 6b. Check programming switches on transmitter.
7. Intrusion alarm for no apparent reason.	7a. Protected door or window opened while system armed. 7b. Improper user operation of exit/entry delays. 7c. Magnets located too far from switches, and/or doors and windows not properly aligned.	7a. Check with all occupants of protected home. 7b. Check setting of entry and exit delays. 7c. Check all openings for proper switch and magnet orientation.
8. "CHECK" and zone number 2-6 are displayed.	8. Control has sensed a high resistance condition on a loop in one of the hardwired zones (2-6).	8. Check the sensor or the loop wiring in the affected zone. The system will not arm until this condition is corrected (or the affected zone is bypassed).

CONTROL

SYMPTOM	POSSIBLE CAUSE	REMEDY
1. AC POWER light off.	1a. Interrupted AC power supply.	1a. Check transformer connection and power line circuit breaker.
2. Digital communicator message not being received.	2a. 250P1 in Test mode. 2b. Telephone connection not secure. 2c. Digital communicator malfunctioning. 2d. Telephone number in program needs prefix or access code. 2e. Telephone call to central monitoring station requires operator assistance.	2a. Remove from Test mode. 2b. Check all connections. 2c. Check with a different 250P1. 2d. Program prefix or access code into the 250P1. 2e. 250P1 system cannot work in this situation.
3. Does not arm properly.	3a. READY light not on.	3a. Check for faulted zones and make intact, or use Bypass arming, if desired.
4. 250P1 doesn't respond to keystrokes on keypad.	4a. CC or MODEM COMM displayed: System is in communication with downloader at Central Station. 4b. dI or SYSTEM BUSY displayed: System has just been powered and is in its 1-minute initialization. 4c. E4 or E8 displayed: More zones have been programmed than the zone Expansion Modules can handle. 4d. Keypad address setting incorrect.	4a. Wait until download session is finished. 4b. To bypass this time, press '#' + '0'. 4c. Delete some zones or use a higher capability RF receiver. 4d. Keypads must be set for address 31 (non-addressable mode).

SMOKE DETECTOR

SYMPTOM	POSSIBLE CAUSE	REMEDY
1. Detector alarms, no apparent reason.	1a. Dust, dirt in sensing chamber. 1b. Improper location. 1c. Unit malfunctioning.	1a. Clean unit's sensing chamber with vacuum cleaner per unit's instructions. 1b. See unit's instructions for locations to avoid. Relocate as necessary. 1c. Replace detector.
2. Detector's siren sounds.	2a. Unit not receiving required power. 2b. Unit malfunctioning.	2a. Check for proper installation of battery. Try new battery. 2b. Replace detector.

CONTACTING TECHNICAL SUPPORT

PLEASE, before you call Technical Support, be sure you:

- **READ THE INSTRUCTIONS!**
- **Check all wiring connections.**
- **Determine that the power supply and/or backup battery are supplying proper voltages.**
- **Verify your programming information where applicable.**
- **Note the proper model number of this product, and the version level (if known) along with any documentation that came with the product.**
- **Note your ADEMCO customer number and/or company name.**

Having this information handy will make it easier for us to serve you quickly and effectively.

You may contact Technical Support via toll-free fax. Please include your return fax number. You will receive a reply within 24 hours. You may also contact Technical Support via modem to ATLAS-BBS, Tech Support's electronic bulletin board system. Replies are posted within 24 hours.

East Coast Technical Support: 1-800-645-7492 (8 am-6 pm EST)

West Coast Technical Support: 1-800-458-9469 (8 am-5 pm PST)

Technical Support Fax Number: 1-800-447-5086

ATLAS-BBS Electronic Bulletin Board System: 1-516-496-3980

(1200 - 9600 Baud, 8 Data Bits, 1 Start/Stop Bit, No Parity)

ATLAS-FAX FAXBACK Automated Fax Retrieval System: 1-800-573-0153 or
1-516-921-6704 / ext. 1667

World Wide Web Address: <http://www.ademco.com>

NOTES

Specifications & Accessories

In This Section

◆ Specifications

◆ Accessories

Specifications

250P1 SECURITY CONTROL

- | | |
|-------------------------------------|---|
| 1. Physical: | 12-1/2" W x 14-1/2" H x 3" D (318mm x 368mm x 76mm) |
| 2. Electrical: | Powerline Carrier device Interface AC Transformer |
| VOLTAGE INPUT: | 16.5VAC from plug-in 25VA transformer, ADEMCO No. 1321 (in USA) |
| RECHARGEABLE BACKUP BATTERY: | 12VDC, 4AH (Sealed Lead Acid).
Charging Voltage: 13.8VDC. |
| ALARM SOUNDER: | 12V, 2.0 Amp output can drive 12V BELLS or can drive one or two 702 (series connected) self-contained 20-watt sirens. Do not connect two 702s in parallel. |
| AUXILIARY POWER OUTPUT: | 12VDC, 600mA max. Interrupts for 4-wire smoke detector reset. |
| NOTE: | For UL installations, Alarm Sounder plus Auxiliary Power currents should not exceed 700mA total. |
| STANDBY TIME: | (see Table in Section 12: Final Power-Up) |
| FUSE: | Battery (3A) No. 90-12 |
| 3. Communication: | |
| FORMAT SUPPORTED: | |
| ADEMCO Contact ID Reporting: | 10 characters/sec., DTMF (TouchTone) Data Tones, 1400/2300Hz ACK, 1400Hz KISSOFF. |
| 4. Maximum Zone Resistance: | Zones 1-6 = 300 ohms excluding EOLR |

6148PL2 REMOTE KEYPAD

- | | |
|-----------------------------|---|
| 1. Physical: | 5-3/4" W x 4-3/8" H x 1-1/8" D (146mm x 111mm x 29mm) |
| 2. Electrical: | Voltage Input: 12VDC; Current Drain: 30mA Standby; 50mA Alarm |
| 3. Interface Wiring: | To control panel's terminal strip connection points: |
| Keypad ConnectorDO: | Terminal 7: Data Output from control to keypad. |
| Keypad Connector+: | Terminal 5: +12VDC |
| Keypad Connector-: | Terminal 4: -12VDC Rtn (Ground) |
| Keypad ConnectorDI: | Terminal 6: Data Input from keypad to control. |

6150PL2 REMOTE KEYPAD

- 1. Physical:** 6-5/8" W x 4-7/8" H x 1-1/4" D (168mm x 124mm x 26mm)
- 2. Electrical:** Voltage Input: 12VDC; Current Drain: 40mA Standby; 100mA Alarm
- 3. Interface Wiring:** Same as 6148PL2 keypad.

6150RFPL2 REMOTE KEYPAD

- 1. Physical:** 6-5/8" W x 4-7/8" H x 1-1/4" D (168mm x 124mm x 26mm)
- 2. Electrical:** Voltage Input: 12VDC; Current Drain: 40mA Standby; 100mA Alarm
- 3. Interface Wiring:** Same as 6150PL2 keypad.

6160PL2 REMOTE KEYPAD

- 1. Physical:** 7-5/16" W x 5-3/8" H x 1-5/16" D (186mm x 137mm x 33mm)
- 2. Electrical:** Voltage Input: 12VDC; Current Drain: 40mA Standby; 130mA Alarm
- 3. Interface Wiring:** Same as 6150RFPL2 keypad.

5881/5882 SERIES RF RECEIVERS (5800 System)

- 1. Physical:** 7-3/8" (188mm) W x 4-3/8" (112mm) H x 1-7/16" (37mm) D
Note: 10-7/8" (277mm) H with antenna
- 2. Electrical:** Voltage Input: 12VDC; Current Drain: 35mA
- 3. Interface Wiring:** To control panel's keypad connection points.
- 4. Range:** 200 ft (60m) **nominal** indoors from wireless transmitters (the actual range to be determined with system in Test mode).
- 5. Zones:** **(With the ADEMCO 250P1)**
5881L/5882L: accepts up to 8 transmitters
5881M/5882M: accepts up to 16 transmitters
5881H/5882H: accepts up to 26 transmitters

5800TM TRANSMITTER MODULE (used with 5827BD Wireless 2-Way Keypad)

- 1. Physical:** 2-1/4" W x 4-1/8" H x 7/8" D (57mm x 105mm x 22mm)
- 2. Electrical:** Voltage Input: 12VDC; Current Drain: 20mA
- 3. Interface Wiring:** To control panel's keypad connection points.

4219 WIRED EXPANSION MODULE

- 1. Physical:** 6-1/2" W x 4-1/4" H x 1-1/4" D (169mm x 108mm x 32mm)
- 2. Electrical:** Voltage Input: 12VDC; Current Drain: 35mA
- 3. Interface Wiring:** To control panel's keypad connection points.
- 4. 8 EOLR Loops (A-H):** Loop A can be set for fast (10–15mSec) response to an open.

4204 RELAY MODULE

- 1. Physical:** 6-1/2" W x 4-1/4" H x 1-1/4" D (169mm x 108mm x 32mm)
- 2. Electrical:** Voltage Input: 12VDC; Current Drain: 15mA (Relays off)
180mA (Relays on)
- 3. Interface Wiring:** To control panel's keypad connection points.
- 4. Four Output Relays:** SPDT Contacts, Rating: 2A max at 28VDC/AC

4229 WIRED EXPANSION/RELAY MODULE

- 1. Physical:** 6-1/2" W x 4-1/4" H x 1-1/4" D (169mm x 108mm x 32mm)
- 2. Electrical:** Voltage Input: 12VDC; Current Drain: 35mA (Relays off)
180mA (Relays on)
- 3. Interface Wiring:** To control panel's keypad connection points.
- 4. 8 EOLR Loops (A-H):** Loop A can be set for fast (10–15mSec) response to an open.
- 5. Two Output Relays:** SPDT Contacts, Rating: 2A max at 28VDC/AC

4285 VIP MODULE

- 1. Physical:** 6-1/2" W x 4-1/4" H x 1-1/4" D (169mm x 108mm x 32mm)
- 2. Electrical:** Voltage Input: 12VDC, Current Drain: 160mA
- 3. DeviceAddress:** Permanently set to address 4.
- 4. Interface Wiring:** See *4285/4286 VIP Module*.
- 5. Telephone Line Connections:** See *4285/4286 VIP Module*.

4286 VIP MODULE

- 1. Physical:** 6-1/2" W x 4-1/4" H x 1-1/4" D (169mm x 108mm x 32mm)
- 2. Electrical:** Voltage Input: 12VDC, Current Drain: 300mA
- 3. DeviceAddress:** Permanently set to address 4.
- 4. Interface Wiring:** See *4285/4286 VIP Module*.
- 5. Telephone Line Connections:** See *4285/4286 VIP Module*.

Accessories (Compatible Devices)

Transformers

- No. 1321** 16.5VAC, 25VA Plug-In Transformer
- No. 4300** Powerline Carrier device Interface AC Transformer

Sounders

- ADEMCO AB-12M** 10" Motor bell & box. UL Grade A. 100mA current draw.
- ADEMCO 1011BE12M** 10" Motor bell & box. UL Listed. 100mA current draw.
- ADEMCO 702** Self-contained 6–12 volt siren (driver built-in) and weatherproof for outdoor use. Can be wired for either a steady or warble sound.
- ADEMCO 719** Two-channel, self-contained 6–12-volt siren (driver built-in). 109dB @ 10 feet. 550mA current draw.
- ADEMCO 747** Self-contained 12-volt siren (driver built-in) for indoor wall mount. 747F available for flush mounting.
- ADEMCO 747UL** Self-contained siren (driver built-in) for indoor wall mount. UL Listed.
- ADEMCO 744** Siren driver with 6 jumper-selected sound outputs. Rated at 119dB with use of an 8-ohm 30 watt speaker.

ADEMCO 745X3	Voice siren driver with English, Spanish, and French voice messages. Separate messages for fire and burglary. Use with 8-ohm speaker. UL Listed.
ADEMCO 705820,	15-watt, 8-ohm, 5" round speaker.
ADEMCO 713	40-watt, 8-ohm, indoor/outdoor speaker.
System Sensor PA400B (beige) PA400R (red)	Indoor piezo sounder (beige or red), rated at 90 dB @ 10 feet.

Compatible 2-Wire Smoke Detectors

System Sensor	
2300T	Photoelectric w/heat sensor, direct wire
2400	Photoelectric, direct wire
2400TH	Photoelectric w/heat sensor, direct wire
2451	Photoelectric w/B401B base
2451TH	Photoelectric w/heat sensor & B401Bbase
1400	Ionization, direct wire
1451	Ionization w/B401B base
2451	Photoelectric duct detector w/DH400 base
1451DH	Ionization duct detector w/DH400 base

Compatible 4-Wire Smoke/Combustion Detectors

System Sensor	
1412	4-wire ionization products of combustion detector
2412	4-wire photoelectric smoke detector
2412TH	4-wire photoelectric smoke detector w/135° F (57° C) heat detector
A77716B	EOL relay module (supervisory module for wired 4-wire fire zone).
2112/24T	Low-profile 4-wire photoelectric smoke detector w/135° F (57° C) heat detector

5800 RF System Wireless Transmitters

Transmitter Input Loop Identification

All of the transmitters illustrated below have one or more unique factory-assigned input (loop) ID codes. Each of the input loops requires its own programming zone (e.g., a 5804's four inputs require four programming zones).

Transmitter inputs entered as:

“RF” (Supervised RF) Type send periodic check-in signals, as well as fault, restore, and low-battery signals. The transmitter must remain within the receiver's range.

“UR” (Unsupervised RF) Type send all the signals that the “RF” type does, but the control does not supervise the check-in signals. The transmitter may, therefore, be carried off-premises.

“BR” (Unsupervised Button RF) Type only send fault signals. They do not send low-battery, restore, or check-in signals. The transmitter may be carried off-premises.

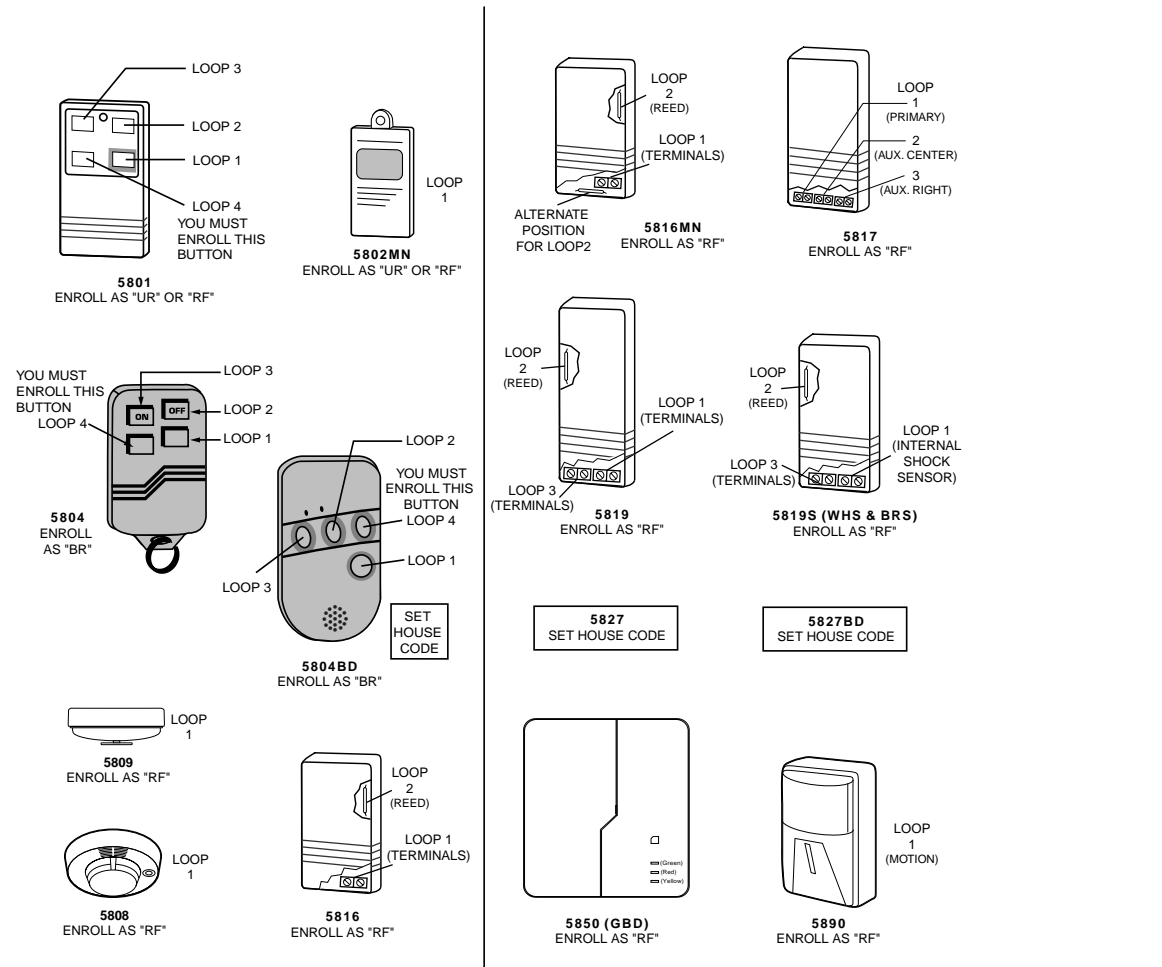

The following transmitters are not intended for use in UL installations:
5802MN, 5804, 5804BD, 5819, 5819WHS/BRS, 5827BD, and 5850.

Regulatory Agency Statements

UL NOTICE: This is a “Grade A” residential system.

FEDERAL COMMUNICATIONS COMMISSION (FCC) Part 15 STATEMENT

This equipment has been tested to FCC requirements and has been found acceptable for use. The FCC requires the following statement for your information:

This equipment generates and uses radio frequency energy and if not installed and used properly, that is, in strict accordance with the manufacturer's instructions, may cause interference to radio and television reception. It has been type tested and found to comply with the limits for a Class B computing device in accordance with the specifications in Part 15 of FCC Rules, which are designed to provide reasonable protection against such interference in a residential installation. However, there is no guarantee that interference will not occur in a particular installation. If this equipment does cause interference to radio or television reception, which can be determined by turning the equipment off and on, the user is encouraged to try to correct the interference by one or more of the following measures:

- If using an indoor antenna, have a quality outdoor antenna installed.
- Reorient the receiving antenna until interference is reduced or eliminated.
- Move the radio or television receiver away from the receiver/control.
- Move the antenna leads away from any wire runs to the receiver/control.
- Plug the receiver/control into a different outlet so that it and the radio or television receiver are on different branch circuits.

If necessary, the user should consult the dealer or an experienced radio/television technician for additional suggestions. The user or installer may find the following booklet prepared by the Federal Communications Commission helpful: “Interference Handbook”

This booklet is available from the U.S. Government Printing Office, Washington, DC 20402.

The user shall not make any changes or modifications to the equipment unless authorized by the Installation Instructions or User's Manual. Unauthorized changes or modifications could void the user's authority to operate the equipment.

FEDERAL COMMUNICATIONS COMMISSION (FCC) Part 68 STATEMENT

This equipment complies with Part 68 of the FCC rules. On the front cover of this equipment is a label that contains, among other information, the FCC registration number and ringer equivalence number (REN) for this equipment. If requested, this information must be provided to the telephone company.

This equipment uses the following jacks: An RJ31X is used to connect this equipment to the telephone network.

The REN is used to determine the quantity of devices which may be connected to the telephone line. Excessive RENs on the telephone line may result in the devices not ringing in response to an incoming call. In most, but not all areas, the sum of the RENs should not exceed five (5.0). To be certain of the number of devices that may be connected to the line, as determined by the total RENs, contact the telephone company to determine the maximum REN for the calling area.

If this equipment causes harm to the telephone network, the telephone company will notify you in advance that temporary discontinuance of service may be required. If advance notice is not practical, the telephone company will notify the customer as soon as possible. Also, you will be advised of your right to file a complaint with the FCC if you believe necessary.

The telephone company may make changes in its facilities, equipment, operations, or procedures that could affect the operation of the equipment. If this happens, the telephone company will provide advance notice in order for you to make the necessary modifications in order to maintain uninterrupted service.

If trouble is experienced with this equipment, please contact the manufacturer for repair and warranty information. If the trouble is causing harm to the telephone network, the telephone company may request you remove the equipment from the network until the problem is resolved.

There are no user serviceable components in this product, and all necessary repairs must be made by the manufacturer. Other repair methods may invalidate the FCC registration on this product.

This equipment cannot be used on telephone company-provided coin service. Connection to Party Line Service is subject to state tariffs.

This equipment is hearing-aid compatible.

When programming or making test calls to an emergency number, briefly explain to the dispatcher the reason for the call. Perform such activities in the off-peak hours; such as early morning or late evening.

Warnings and Limitations

WARNING

THE LIMITATIONS OF THIS ALARM SYSTEM

While this System is an advanced design security system, it does not offer guaranteed protection against burglary, fire or other emergency. Any alarm system, whether commercial or residential, is subject to compromise or failure to warn for a variety of reasons. For example:

- Intrusion detectors (e.g., passive infrared detectors), smoke detectors, and many other sensing devices will not work without power. Battery-operated devices will not work without batteries, with dead batteries, or if the batteries are not put in properly. Devices powered solely by AC will not work if their AC power supply is cut off for any reason, however briefly.
- Signals sent by wireless transmitters may be blocked or reflected by metal before they reach the alarm receiver. Even if the signal path has been recently checked during a weekly test, blockage can occur if a metal object is moved into the path.
- A user may not be able to reach a panic or emergency button quickly enough.
- While smoke detectors have played a key role in reducing residential fire deaths in the United States, they may not activate or provide early warning for a variety of reasons in as many as 35% of all fires, according to data published by the Federal Emergency Management Agency. Some of the reasons smoke detectors used in conjunction with this System may not work are as follows. Smoke detectors may have been improperly installed and positioned. Smoke detectors may not sense fires that start where smoke cannot reach the detectors, such as in chimneys, in walls, or roofs, or on the other side of closed doors. Smoke detectors also may not sense a fire on another level of a residence or building. A second floor detector, for example, may not sense a first floor or basement fire. Finally, smoke detectors have sensing limitations. No smoke detector can sense every kind of fire every time. In general, detectors may not always warn about fires caused by carelessness and safety hazards like smoking in bed, violent explosions, escaping gas, improper storage of flammable materials, overloaded electrical circuits, children playing with matches, or arson. Depending on the nature of the fire and/or location of the smoke detectors, the detector, even if it operates as anticipated, may not provide sufficient warning to allow all occupants to escape in time to prevent injury or death.
- Passive Infrared Motion Detectors can only detect intrusion within the designed ranges as diagrammed in their installation manual. Passive Infrared Detectors do not provide volumetric area protection. They do create multiple beams of protection, and intrusion can only be detected in unobstructed areas covered by those beams. They cannot detect motion or intrusion that takes place behind walls, ceilings, floors, closed doors, glass partitions, glass doors, or windows. Mechanical tampering, masking, painting or spraying of any material on the mirrors, windows or any part of the optical system can reduce their detection ability. Passive Infrared Detectors sense changes in temperature; however, as the ambient temperature of the protected area approaches the temperature range of 90° to 105°F (32° to 40°C), the detection performance can decrease.
- Alarm warning devices such as sirens, bells or horns may not alert people or wake up sleepers if they are located on the other side of closed or partly open doors. If warning devices are located on a different level of the residence from the bedrooms, then they are less likely to waken or alert people inside the bedrooms. Even persons who are awake may not hear the warning if the alarm is muffled by noise from a stereo, radio, air conditioner or other appliance, or by passing traffic. Finally, alarm warning devices, however loud, may not warn hearing-impaired people.
- Telephone lines needed to transmit alarm signals from a premises to a central monitoring station may be out of service or temporarily out of service. Telephone lines are also subject to compromise by sophisticated intruders.
- Even if the system responds to the emergency as intended, however, occupants may have insufficient time to protect themselves from the emergency situation. In the case of a monitored alarm system, authorities may not respond appropriately.
- This equipment, like other electrical devices, is subject to component failure. Even though this equipment is designed to last as long as 20 years, the electronic components could fail at any time.

The most common cause of an alarm system not functioning when an intrusion or fire occurs is inadequate maintenance. This alarm system should be tested weekly to make sure all sensors and transmitters are working properly. The security keypad (and remote keypad) should be tested as well.

Wireless transmitters (used in some systems) are designed to provide long battery life under normal operating conditions. Longevity of batteries may be as much as 4 to 7 years, depending on the environment, usage, and the specific wireless device being used. External factors such as humidity, high or low temperatures, as well as large swings in temperature, may all reduce the actual battery life in a given installation. This wireless system, however, can identify a true low battery situation, thus allowing time to arrange a change of battery to maintain protection for that given point within the system.

Installing an alarm system may make the owner eligible for a lower insurance rate, but an alarm system is not a substitute for insurance. Homeowners, property owners and renters should continue to act prudently in protecting themselves and continue to insure their lives and property.

We continue to develop new and improved protection devices. Users of alarm systems owe it to themselves and their loved ones to learn about these developments.

ADEMCO LIMITED WARRANTY

Alarm Device Manufacturing Company, a Division of Pittway Corporation, and its divisions, subsidiaries and affiliates ("Seller"), 165 Eileen Way, Syosset, New York 11791, warrants its products to be in conformance with its own plans and specifications and to be free from defects in materials and workmanship under normal use and service for 24 months from the date stamp control on the product or, for products not having an Ademco date stamp, for 12 months from date of original purchase unless the installation instructions or catalog sets forth a shorter period, in which case the shorter period shall apply. Seller's obligation shall be limited to repairing or replacing, at its option, free of charge for materials or labor, any product which is proved not in compliance with Seller's specifications or proves defective in materials or workmanship under normal use and service. Seller shall have no obligation under this Limited Warranty or otherwise if the product is altered or improperly repaired or serviced by anyone other than Ademco factory service. For warranty service, return product transportation prepaid, to Ademco Factory Service, 165 Eileen Way, Syosset, New York 11791.

THERE ARE NO WARRANTIES, EXPRESS OR IMPLIED, OF MERCHANTABILITY, OR FITNESS FOR A PARTICULAR PURPOSE OR OTHERWISE, WHICH EXTEND BEYOND THE DESCRIPTION ON THE FACE HEREOF. IN NO CASE SHALL SELLER BE LIABLE TO ANYONE FOR ANY CONSEQUENTIAL OR INCIDENTAL DAMAGES FOR BREACH OF THIS OR ANY OTHER WARRANTY, EXPRESS OR IMPLIED, OR UPON ANY OTHER BASIS OF LIABILITY WHATSOEVER, EVEN IF THE LOSS OR DAMAGE IS CAUSED BY THE SELLER'S OWN NEGLIGENCE OR FAULT.

Seller does not represent that the products it sells may not be compromised or circumvented; that the products will prevent any personal injury or property loss by burglary, robbery, fire or otherwise; or that the products will in all cases provide adequate warning or protection. Customer understands that a properly installed and maintained alarm may only reduce the risk of a burglary, robbery, fire or other events occurring without providing an alarm, but it is not insurance or a guarantee that such will not occur or that there will be no personal injury or property loss as a result. CONSEQUENTLY, SELLER SHALL HAVE NO LIABILITY FOR ANY PERSONAL INJURY, PROPERTY DAMAGE OR OTHER LOSS BASED ON A CLAIM THE PRODUCT FAILED TO GIVE WARNING. HOWEVER, IF SELLER IS HELD LIABLE, WHETHER DIRECTLY OR INDIRECTLY, FOR ANY LOSS OR DAMAGE ARISING UNDER THIS LIMITED WARRANTY OR OTHERWISE, REGARDLESS OF CAUSE OR ORIGIN, SELLER'S MAXIMUM LIABILITY SHALL NOT IN ANY CASE EXCEED THE PURCHASE PRICE OF THE PRODUCT, WHICH SHALL BE THE COMPLETE AND EXCLUSIVE REMEDY AGAINST SELLER. This warranty replaces any previous warranties and is the only warranty made by Seller on this product. No increase or alteration, written or verbal, of the obligations of this Limited Warranty is authorized.

Index

1011BE12M.....	26-1, 26-3	5800TM.....	6-3
1321.....	1-4, 2-5	5800TM Transmitter Module.....	6-3
1321 AC Transformer.....	1-2, 7-3	5800TM Wiring.....	6-3
1321 Transformer.....	12-1	5801.....	6-4, 6-5
1400.....	26-4	5801 Button.....	6-4
1412.....	26-4	5802.....	6-4, 6-5, 23-5
1412 Combustion Detector.....	4-3	5802CP.....	6-4, 6-5, 23-5
1451.....	26-4	5802MN.....	6-4
1451DH.....	26-4	5803.....	6-4, 6-5, 23-5
1-Minute Delay.....	12-1	5803 Button.....	6-4
2112/24T.....	26-4	5804 Button.....	6-4
2112/24T Photoelectric Detector.....	4-3	5804 Keypad.....	6-3
2300T.....	26-4	5804BD.....	6-1
2400.....	26-4	5804BD Button.....	6-4
2400TH.....	26-4	5804BD Keypad.....	6-3, 15-1
2412.....	26-4	5816 Transmitter.....	6-3
2412 Photoelectric Detector.....	4-3	5817.....	25-2
2412TH.....	26-4	5817 Transmitter.....	6-3
2412TH Photoelectric. Detector.....	4-3	5827.....	6-1, 6-3, 6-4, 6-7, 25-1
2451.....	26-4	5827 Wireless Keypad.....	6-3
2451TH.....	26-4	5827BD.....	6-1, 6-4, 25-1
24-Hour Audible Alarm.....	14-2	5827BD Keypad.....	6-3
24-Hour Auxiliary Alarm.....	14-2	5881.....	6-2
24-Hour Silent Alarm.....	14-2	5881/5882.....	25-1
2-Digit Phone Code.....	8-4	5881H.....	6-1
2-Wire Smoke Detectors.....	4-2, 26-4	5881H/5882H.....	1-1
4142TR Cable.....	2-5, 7-4	5881L.....	6-1
4204.....	11-1, 13-2, 23-4	5881L/5882L.....	1-1
4204 Relay Module.....	1-2, 17-3	5881M.....	6-1
4219 Expansion Unit.....	5-1	5881M/5882M.....	1-1
4229.....	1-1, 11-1, 13-2	5882.....	1-1, 6-2
4229 Expansion Unit.....	5-1	5882H.....	6-1
4229 Relay Module.....	1-2, 17-3	6148PL2.....	1-1
4285.....	8-4, 11-1	6150PL2.....	1-1
4285 VIP Module.....	8-1, 19-1	6150RFPL2.....	1-1
4285 Wiring.....	8-2	6160PL2.....	1-1, 1-4
4285/4286 Installation.....	8-1	702.....	26-3
4285/4286 VIP Module.....	1-3, 2-4	705-820.....	26-4
4285/4286 VIP Module Checkout.....	8-4	713.....	26-4
4285/4286 VIP Module Programming.....	8-4	719.....	26-3
4286.....	8-4, 11-1	744.....	26-3
4286 VIP Module.....	8-1, 19-1	745X3.....	26-4
4286 Wiring.....	8-2	747.....	26-3
4300 Transformer.....	1-2, 2-5, 7-1, 7-3	747UL.....	26-3
4300 Transformer Module.....	1-4	7720PLUS.....	1-3, 10-1
467 Battery.....	12-1	7820.....	1-3
487-12 Power Supply.....	3-2	7820 LRR.....	10-1
488-12 Power Supply.....	3-2	A77-716B.....	26-4
4-Wire Smoke Detectors.....	4-1, 4-2, 4-3	A77-716B Supervisory. Module.....	4-3
4-Wire Smoke/Combustion Detectors.....	26-4	AAV.....	1-3, 11-1
5800 Series Transmitters.....	6-3, 6-4, 6-6	AAV Wiring Connections.....	11-1

Index

AC Loss Report Code	15-8	Basic Hardwired Zones	1-1, 4-1
AC Power Supply	1-4	Battery Connector Cable	12-2
AC Restore Report Code	15-8	Battery Life	6-4
AC Transformer	2-5	Battery Size Calculation.....	12-2
ADEMCO 1011BE12M.....	9-1	Battery Standby Formula.....	12-2
ADEMCO 702.....	9-1	Battery, Sealed Lead Acid	26-1
ADEMCO 705-820	9-1	Bell Supervision	9-2
ADEMCO 713 Speaker.....	9-1	Bells	9-2
ADEMCO 719 Siren.....	9-1	Busy-Standby	3-3
ADEMCO 744.....	9-1	Button transmitters.....	6-4
ADEMCO 745X3	9-1	Bypass Report Code	15-7
ADEMCO 747.....	9-1	Bypass Restore Report Code	15-8
ADEMCO 747UL Siren	9-1	Bypassing Zones.....	23-2
ADEMCO AB-12M.....	9-1	Caller ID Unit.....	8-2, 8-3
ADEMCO AB-12M.....	26-1, 26-2, 26-3	CANCEL ALARM Message	15-6
ADEMCO COMPASS	1-3	Cancel Report Code.....	15-8
ADEMCO Contact ID	1-4	Cancel Verify.....	15-6
ADEMCO Contact ID Reporting Format	22-2	Central Station.....	4-1, 15-7
ADEMCO Model 610-7	4-2	Character List	19-3
Alarm Bell Timeout	15-3	Charging Voltage	26-1
Alarm Output.....	1-3, 9-2	CHECK 09 Message.....	5-3
Alarm Output.....	12-2	CHECK Condition.....	4-1
Alarm Response- Off.....	14-3	CHECK Message.....	1-2, 7-2
Alarm Restore Report Code.....	15-8	CHECK ZONE Message	15-3
Alarm Sounders	9-2	Checked Notes	viii
Alpha Descriptor	19-3	Check-In Signal.....	6-4
Alpha Descriptor Programming.....	19-1	Checkout Procedure	4-4
Alpha Display Keypad.....	3-1	Chime By Zone	15-2
Alpha keypad.....	1-1	Chime Mode.....	23-3
Alpha Keypad.....	13-2	Clock Mode	23-6
Alpha Programming	13-2	Communication Failure.....	23-5
Alpha Vocabulary List.....	19-1, 19-2, 19-4	COMPASS® Downloader.....	21-2
Answering Machine	15-12	COMPASS® Software.....	21-1
Antennas.....	2-3	Compatible Sounders.....	9-1
Arm Away/Stay Report Code	15-8	Confirmation Option.....	16-3
Arm-Away.....	14-3	Contact ID	10-1, 15-7, 22-2
Arming Away.....	23-2	Contact ID Event Codes	22-2
Arming Commands	23-2	Control's Circuit Board.....	2-2
Arming Ding Confirmation	15-4	Conventions.....	viii
Arming Instant.....	23-2	Cross Zone Timer	15-10
Arming Maximum.....	23-2, 23-3	Cross Zoning - Zone List 04	18-2
Arming Modes	23-3	Custom Alpha Editing	15-9
Arming Stay	23-2	Custom Words	19-3, 4
Arm-Stay.....	14-3	Data Field Descriptions.....	15-1
ASCII Character Chart	19-1, 4	Data Field Programming.....	13-1, 13-2
ATLIS-BBS.....	25-3	Data Fields	viii
Audible Exit Warning.....	15-4	Daylight Saving Time Start/End	15-9
Audio Alarm Verification (AAV)	1-3, 8-2, 11-1	Default Descriptor.....	19-2
Auto Stay Arming	15-10	Delete Serial Number	16-7
Auxiliary Device Worksheet.....	12-2	Description.....	1-1
Auxiliary Output.....	12-2	Device Address	5-1
Auxiliary Power Output	1-4	dI	3-3, 12-1
Backup Battery	1-4, 2-6, 9-2, 12-1	Dialer Delay (Burg/Fire).....	15-5
Backup Battery Installation.....	2-6	Dialer Programming	15-4

DIP Switch	5-1, 6-2, 7-2	Features	1-1
DIP Switch	6-3, 6-7	Final Power-Up	12-1
DIP switches.....	6-6	Fire Alarm Sounding	4-3
Direct-Connect Cord.....	8-2	Fire Sounder Timeout.....	15-3
Disarm	14-3	Fixed-Word Keypads.....	1-1, 3-1
Disarmed, Not Ready.....	23-2	Forced (Quick) Bypass	23-2
Disarmed...Not Ready to Arm Message.....	8-4	Forced Bypass.....	15-1
Disarming.....	23-2	Function Key Defaults.....	20-2
Download Information.....	15-12	Function Key Programming.....	15-9, 20-1
Download Phone Number.....	15-12	Go/No Go Test Mode	6-7, 24-2
Downloader.....	6-3	Grounding Lugs.....	2-3
Downloading.....	21-2	Handshake.....	21-1, 22-1
DSD.....	10-2, 15-9	Hardwire Short Detection	1-2
DSP	10-2, 15-9	HAYES Modem	1-4, 21-1
Duress code.....	1-2	House ID	6-1, 6-7
Dynamic Signaling Delay	10-2	IBM Personal Computer	21-1
Dynamic Signalling.....	15-9	Ideal Model 61-035	2-6, 12-1
Dynamic Signalling Priority	10-2	Initialize Download ID.....	15-13
E344 Report.....	6-3	Installer Code	15-1
Eagle 1241	11-1	Installing the Control	2-1
Earth Ground.....	2-6, 12-1	Intellimodem 1200	21-2
EE Message.....	13-2	Intellimodem 2400	21-2
Enrolling.....	6-3, 6-6, 16-1, 16-8	Interactive Mode	6-3
Enrolling.....	6-4	Interactive Mode Programming	13-2
Entry Delay	14-3	Interior Follower	14-2
Entry Delay 1	15-3	Interior w/Delay	14-3
Entry Delay 2	15-4	Introduction.....	1-1
ENTRY ERROR Message.....	13-2	Jam Detection and Reporting.....	6-3
Entry/Exit Burglary.....	14-1	Keypad Connections.....	3-2
Entry/Exit Burglary.....	2	Keypad Display Prompts.....	viii
EOL Resistor	3-3, 4-2, 4-3, 4-4, 5-3	Keypad Functions	23-2
EOL Supervision.....	6-3	Keypad Panic Keys	1-2
EOLR	4-1, 5-1	Keypad Wiring	3-1
Event Log 80% Full Report Code.....	15-11	Keypads	3-2
Event Logging	1-3, 15-11	Kiss Off	11-1, 15-6
Exit Alarm.....	1-2	Kissoff	22-1
EXIT ALARM Message.....	15-7	Line Seizure Wiring	8-3
Exit Delay.....	15-3	Lock installation.....	2-1
Exit Error Alarm.....	23-4	Long Range Radio	1-3, 10-1
Exit Error Report Code.....	15-7	Loop.....	6-3, 6-4, 16-6
Exit Restart	1-2	Low Bat Report Code	15-8
Exiting Programming Mode	15-13	Low Bat Restore Report Code	15-8
Expert Mode Programming.....	16-4	Low Battery Message.....	25-1
Expert Programming Mode	15-7	LOW BATTERY Message.....	12-2
External Sounders	9-1	LRR Communication Failure	23-5
Factory Defaults.....	13-3	Macro Key Programming.....	20-3
False Alarm Prevention.....	1-2	Magnet.....	25-2
Fast Busy Signal.....	8-3	Master Code.....	23-1
FAULT.....	4-1	Mechanics of Programming.....	13-1
FAULT Condition	4-1	Memory-of-Alarm	4-3
FAULT ZONE Message.....	15-3	Model Numbers	viii
FCC	B-2	Modem	13-1
FCC (Part 68).....	B-2	Monitored Telephone Line.....	23-5

Index

Mounting Clips.....	2-2, 2-3	Pulse Dialing,	8-1
Night-Stay - Zone List 05	18-2	Quick Arm Enable.....	15-1
No. 1321	26-1, 26-3	Rcvr Jam Message	6-3
No. 4300.....	26-1, 26-3	READY LED.....	3-4
OC Message.....	3-4	READY TO ARM Message	4-4, 5-3
Off-Premises Phone	8-4	Real-Time Clock.....	23-6
On-Premises Phone.....	8-4	Receiver Supervision.....	6-1
OPEN CIRCUIT Message	3-4	Relay ACTION	7-1, 7-4, 17-1
Open Report Code	15-8	Relay Outputs.....	7-1
Optima 24 Plus FAX96 Modem.....	21-2	Relay Programming	13-2
Optima 2400 Fax96.....	21-2	Relay START	7-1, 7-4, 17-1
Optima 336 External	21-2	Relay STOP	7-1, 7-4, 17-2
Option Selection.....	15-11	Relays.....	7-1
Optional Phone Modules	1-3	Remote Keypad Installation.....	3-1
Output Device Menu Mode.....	17-3	Remote Keypads.....	1-1
Output Devices.....	15-9	Remote Programming.....	21-1
Output Devices Programming.....	17-1	Report Code	15-7, 16-2
Output Relay Programming.....	17-3	Report Code Formats.....	22-1
Output Relays	1-2	Report Codes	15-7
Output to Long Range Radio.....	15-2	Report Format.....	15-5
PA400B.....	26-4	Response Time.....	4-1
PA400B Piezo Sounder.....	9-1	Restore	15-8
PA400R.....	26-4	Restore Report Code Programming	15-7
PA400R Piezo Sounder.....	9-1	RF.....	6-4
PABX Access Code	15-4	RF House ID.....	6-4
Pager Characters	15-10	RF House ID Code.....	15-1
Pager Delay Timer	15-10	RF Interference (RFI)	6-2
Pager Format	15-10	RF Receiver	6-2
Pager Phone No.....	15-6	RF System	13-1, 13-3, 15-1
Pager Report Options	15-6	RF XMTR Low Bat Report Code.....	15-8
Pager Reporting - Zone List 06	18-2	RF XMTR Low Bat Restore Code.....	15-9
Paging Feature.....	1-3	Ring Detection Count for Downloading.....	15-12
Panic Keys	23-3	RJ31X Jack.....	2-4, 8-2, 8-3, B-2
Perimeter Burglary.....	14-1	Secondary Phone No.	15-4
Periodic Test Report	15-5	Secondary Subscriber Account No.	15-5
Phone Line.....	2-4	Secondary User Codes	23-1
Phone Line Monitor Enable	15-12	Security Codes.....	1-2, 23-1
Phone Module.....	2-4, 8-2, 8-3, 15-12, 23-4	Sequential Mode.....	13-2
Phone Module Access Code	15-2	Serial Number	25-1
Phone System Select.....	15-5	Serial Number	16-7
Power Failure.....	23-5	Serial Number Removal	16-5
POWER LED.....	3-4	Sescoa/Radionics Select	15-6
Power Up in Previous State	15-4	Setting Program Fields to Default Values ...	15-13
Powerline Carrier Device	1-2, 7-1, 17-3, 17-4	Short Detection	15-3
Practical Peripherals	21-2	Silent Burglary.....	14-3
Preliminary Checkout.....	3-3	Silent Panic	23-3
Primary Phone No.	15-4	Single Alarm Sounding.....	15-3
Primary Subscriber Account No.	15-5	Sirens	9-2
Program Mode Exiting.....	13-2	Smartmodem 1200	21-2
Program Mode Start	13-2	Smartmodem 1200B	21-2
Programming.....	1-4, 13-1	Smartmodem Optima 2400	21-2
Programming Hardwired Zones.....	4-4	Sniffer Mode	6-5
Programming Information	13-1	Sounder Supervision.....	9-2
Programming Procedures.....	20-1	Sounder Testing	9-2

Sounders.....	9-2, 26-1, 26-2, 26-3	Trouble Restore	15-2
Special Function Programming	15-10, 20-2	Trouble Restore Report Code	15-8
Speedkey.....	20-3	UL	2-6, 6-3, 7-3, 9-1, 10-1, 12-2, B-2
Split/Dual Reporting.....	15-5	UL Notes.....	viii
Star	viii	Unsupervised Button.....	6-4
Subscriber Account No.	15-13	Unsupervised RF.....	6-4
Supervised Fire	14-2	Verifying Detector Operation.....	4-3
Supervised RF	6-4	Voice Messages.....	8-1
Supervision.....	7-2	Warning Symbols	viii
Supplementary Power Supply.....	3-2	Wired Expansion	1-1
Swinger Suppression	15-12	Wired Zone Expansion.....	13-1, 13-3, 15-2
System Communication.....	22-1	Wireless Expansion.....	1-1
System Operation	23-1	Wireless Expansion Zones	6-1
System Operation Choices.....	17-4	Wireless Keys	6-3, 16-9
System Status Programming	15-7	Wireless Transmitters	6-1
System Status Report Codes.....	15-7	Wiring Length/Gauge Chart.....	3-1
Tamper Protection	5-1, 6-4	Wiring Run Chart	3-1
Technical Support Contact.....	25-3	Word String	19-3
Telco Hand-off	21-1	X10	1-2, 15-2
Telco Line	8-3	X-10	1-4, 17-4
Telephone Line Monitoring.....	1-3	Xmtr Serial Number Removal.....	16-7
Temporal Pulse Sounding	9-1	ZONE 09 Message.....	7-2
Temporary Code.....	1-2	Zone Default Values.....	16-2
Temporary User Code.....	23-1	Zone Descriptor Programming.....	19-1
Test Mode	24-1	Zone Descriptors.....	1-4, 19-1, 19-4
Test Report Code.....	15-8	Zone Expansion	5-1
Test Report Offset.....	15-6	Zone List	13-2
Test Restore Report Code.....	15-9	Zone List Displays.....	18-1
TouchTone	8-1	Zone List Menu	18-1
TouchTone Phone.....	8-4	Zone Lists for Output Devices.....	15-9
Transformer	26-3	Zone Monitor Features	1-2
Transformer Wiring Table	2-5	Zone Not Used.....	14-1
Transmitter Input Types.....	6-4	Zone Programming.....	13-2, 16-1
Transmitter Sniffer Mode.....	24-1, 25-1	Zone Programming Mode	15-6
Transmitter Supervision	6-4	Zone Removable	16-6
Trouble by Day	14-2	Zone Type Choices.....	17-4
Trouble Condition	23-4	Zone Type Definitions.....	14-1
Trouble Report Code	15-7	Zone Types.....	14-1, 16-2

Figure 22. 250P1 Summary of Connections

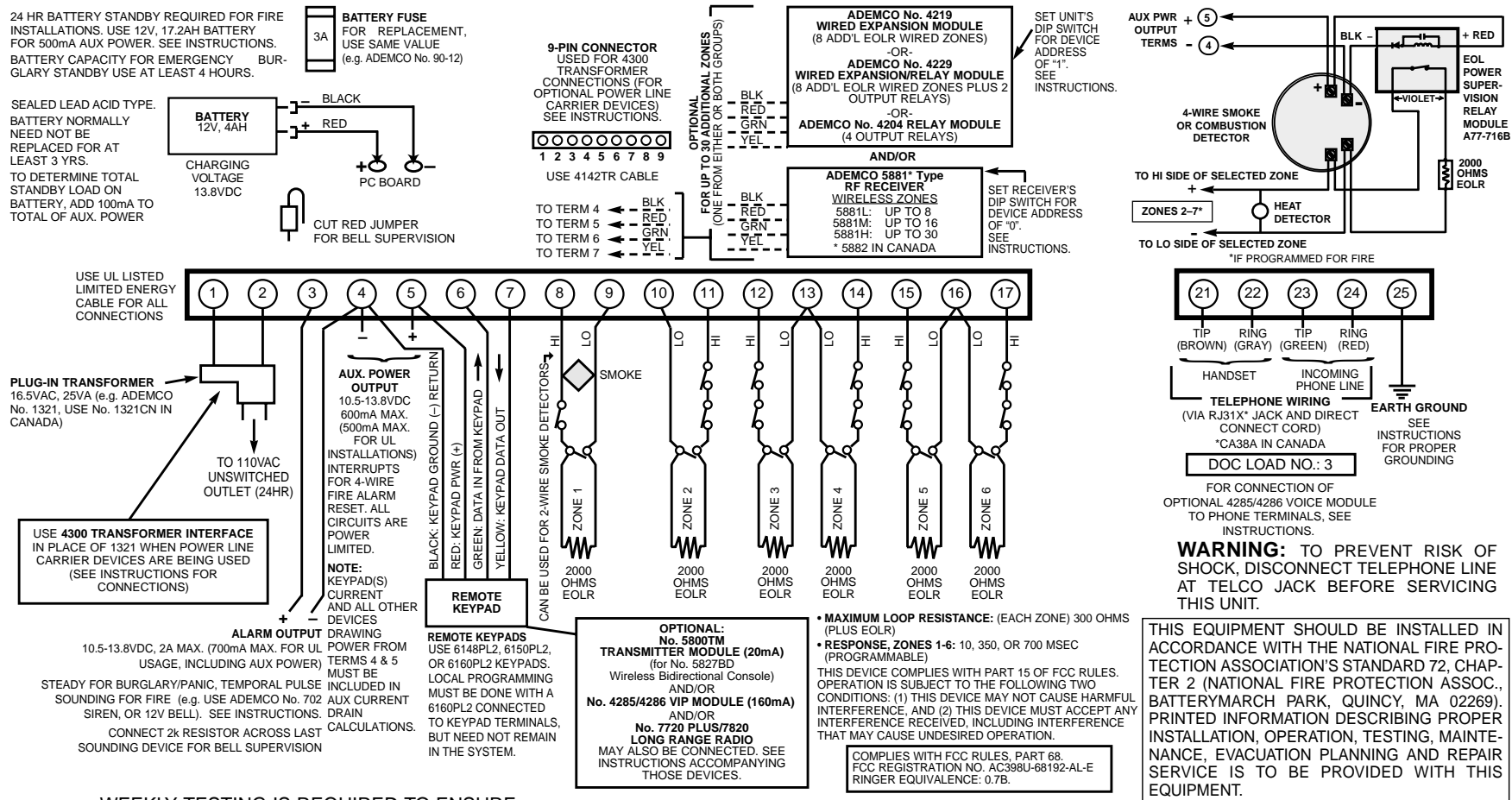

WEEKLY TESTING IS REQUIRED TO ENSURE PROPER OPERATION OF THIS SYSTEM.

250P1 SUMMARY OF CONNECTIONS



600 Corporate Pointe

Cullver City, CA 90230

Tel: (800) 738-4255



K4331 9/99